

Shown with optional USB Interface Daughterboard

# ASSEMBLY MANUAL - RAAS-8a Remote Automatic Antenna Switch Kit

## Revision History

Revision Number	Date	Description	Notes
1.1	2/14/2022	<ul style="list-style-type: none"> <li>Moved small component assembly steps up in the order to allow for easier insertion and soldering.</li> <li>Assorted minor grammar and image editing.</li> </ul>	As per suggestion from Mark – K4SO
1.2	2/15/2022	<ul style="list-style-type: none"> <li>Modified step 88 to add “(or, approximately 200kΩ if using the meter’s resistance setting)”</li> <li>Changed the stripe color of the Zener diodes from white to black.</li> </ul>	<p>for more accuracy on the antenna selection tests</p> <p>To reflect the new Zener diode version</p>
1.3	2/21/2022	<ul style="list-style-type: none"> <li>Added soldering hint for installing the 8-pin headers used by the USB Interface Module.</li> </ul>	As per suggestion from Frank – W4TG
1.4	3/5/2022	<ul style="list-style-type: none"> <li>Changed all microcontroller references to a generic PIC model due to varying availability of individual models.</li> <li>Changed the version number and photo of the optional USB Interface Module in the Main Board Parts Inventory to reflect the newest version.</li> <li>Changed photos to reflect new power switch cable and CN3 header assembly.</li> <li>Added a check to the optional USB interface final installation step to ensure the switch model jumper is installed correctly.</li> </ul>	
1.5	3/12/2022	<ul style="list-style-type: none"> <li>Corrected the jumper setting for the USB Interface Module so that it reflected the correct kit model (RAAS-8)</li> </ul>	Copy and paste error from the RAAS-4 Manual.
1.6	3/10/2023	<ul style="list-style-type: none"> <li>Changed parts inventory photos to reflect changes to several components related to supply chain issues.</li> <li>Changed parts inventory photo for the trimmer resistor R71 to reflect changes made to make the Icom Band Data adjust less touchy.</li> </ul>	
1.7	5/25/2023	<ul style="list-style-type: none"> <li>Changed the sequence for plugging in the front panel ribbon cables so that they are already attached before mounting the front panel circuit board to the enclosure.</li> <li>Added fuse holder and ½ amp fuse to parts list as well as the steps to install same. Updated the main circuit board version number accordingly.</li> </ul>	
1.8	8/25/2023	<ul style="list-style-type: none"> <li>Updated circuit board version numbers in the parts list.</li> </ul>	

**CONTENTS**

Getting Started .....1

    Required Tools and supplies .....1

    Recommended Tools .....1

    Parts Inventory .....1

    Tips for Successful Soldering .....8

Circuit Board Assembly .....10

    Controller Main Board .....10

    Controller Front Panel .....15

    Remote Antenna Relay Board .....17

Final Assembly .....20

    Controller .....20

        Front Panel .....20

        Main Board .....20

        Power Switch and Ribbon Cables .....21

        Adjust Icom Band Data Voltage Divider .....22

        Install PIC Microcontroller Chip .....23

    Remote Antenna Relay Box .....24

        Mounting the Circuit Board .....24

        Installing the 100kΩ Resistors .....27

Testing .....28

    Manual Mode .....28

    Auto Mode .....29

    Remote Relay Box .....30

Troubleshooting .....32

Schematic Diagrams .....38

## GETTING STARTED

These instructions are specifically structured to guide you through the steps required to easily complete the assembly of the remote antenna switch. The order of the sections and steps has been chosen to reduce any instances where awkward soldering or physical assembly would be needed. For instance, resistors are installed early in the main board assembly since they sit very close to the circuit board and have less chance of interfering with component placement while installing any later components such as the transistors and voltage regulators.

There are no “hard” soldering tasks on this kit. Anyone with beginner-level or better soldering skills should be able to successfully complete that portion of the assembly.

## REQUIRED TOOLS AND SUPPLIES

The following tools and supplies are required to complete the assembly of the remote antenna switch:

- Soldering Iron – At least 60 watts with a thin tip is recommended. A temperature-controlled soldering station would be preferred.
- Rosin core solder – please see the soldering tips section below for a discussion on choosing between leaded or non-leaded solder compositions.
- #1 and #2 phillips-head screw drivers
- Small straight-slot screwdriver – used to adjust a variable resistor, so a blade width of 1/8” to 3/16” is recommended.
- Small needle-nosed pliers
- Small diagonal wire cutters
- Nut drivers (or sockets/wrenches) in the following sizes: 3/16”, 1/4”, 5/16”, 3/8”
- Wire strippers
- Multi-meter w/ test leads (not shown)



Figure 1 - Required Hand Tools

## RECOMMENDED TOOLS





The following tools are recommended to make the assembly process easier and more precise, but are not required:





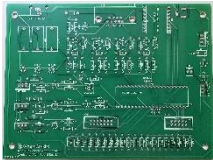







- “Helping Hands” station equipped with a magnifying glass.

## PARTS INVENTORY







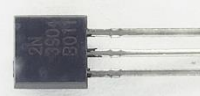

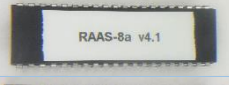

After unpacking all kit components and hardware, please refer to the following tables to ensure everything has been included and identified before moving to the actual assembly sections of this manual. If anything is missing, please contact the seller for replacements.

Table 1 – Controller Main Board Parts

<input checked="" type="checkbox"/>	Component	Qty	Circuit Designator(s)	Identifying Marks	Image
<input type="checkbox"/>	Controller Enclosure	1	Only provided with kits where the enclosure was purchased as part of the kit.	N/A	
<input type="checkbox"/>	Circuit Board – Controller Main Board	1	N/A	Rev 6.4	
<input type="checkbox"/>	DC Power Jack	1	J1_12V_TO_30V	N/A	
<input type="checkbox"/>	12V 1A DC Power Supply Wall AC Adapter	1	N/A	N/A	
<input type="checkbox"/>	DB-9 Male Right Angle Socket	1	J2_BAND_DATA	N/A	
<input type="checkbox"/>	DB-9 Female connector	1	N/A	N/A	
<input type="checkbox"/>	DB-9 Connector Backshell Assy	1	N/A	N/A	
<input type="checkbox"/>	Fuse Holder <b>(main circuit board version 6.3 or later)</b>	2	FH1, FH2	N/A	
<input type="checkbox"/>	1/2 Amp fuse 1/4" dia. X 3/4" long <b>(main circuit board version 6.3 or later)</b>	1	N/A	500mA L 250V	
<input type="checkbox"/>	RJ11 6P4C socket	1	J3_TO_RELAYS	N/A	

<input checked="" type="checkbox"/>	Component	Qty	Circuit Designator(s)	Identifying Marks	Image
<input type="checkbox"/>	RJ11 6P4C Plug	1	N/A	N/A	
<input type="checkbox"/>	0.1 µf Ceramic Disk Capacitor	10	C1, C2, C4, C5, C6, C8, C9, C10, C11, C12	104	
<input type="checkbox"/>	.33 µf Ceramic Disk Capacitor	1	C3	334 CSK (but may vary)	
<input type="checkbox"/>	.1 µf 1kV Capacitor	3	C17, C18, C19	104J1000V	
<input type="checkbox"/>	330Ω ¼ Watt Resistor	10	R35, R47, R48, R49, R50, R51, R52, R53, R54, R55	orange / orange / brown / gold (Resistor body color may vary)	
<input type="checkbox"/>	1kΩ ¼ Watt Resistor	14	R3, R7, R11, R16, R19, R20, R23, R24, R27, R28, R31, R33, R34, R45	brown / black / red / gold	
<input type="checkbox"/>	3.3kΩ ¼ Watt Resistor	3	R13, R14, R15	Orange / orange / red / gold	
<input type="checkbox"/>	4.7kΩ ¼ Watt Resistor	13	R1, R5, R9, R32, R60, R61, R62, R63, R64, R65, R66, R67, R68	yellow / violet / red / gold	
<input type="checkbox"/>	10kΩ ¼ Watt Resistor	16	R2, R4, R6, R8, R10, R12, R17, R18, R21, R22, R25, R26, R29, R30, R36, R70	brown / black / orange / gold	
<input type="checkbox"/>	20kΩ Trimmer Resistor	1	R71	W203 13H	
<input type="checkbox"/>	1N4001 Diode	1	D5	1N4001 MDO	
<input type="checkbox"/>	3V Zener Diode	4	D1, D2, D3, D4	N/A	
<input type="checkbox"/>	3mm Red Light Emitting Diode	3	BIT_0, BIT_1, BIT_2	N/A	
<input type="checkbox"/>	2N3904 NPN Transistor	7	Q1, Q2, Q3, Q4, Q5, Q6, Q7	2N3904 B011	

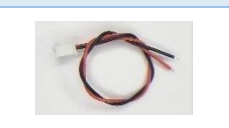
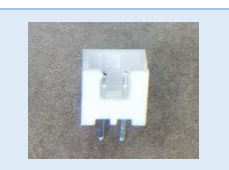

<input checked="" type="checkbox"/>	Component	Qty	Circuit Designator(s)	Identifying Marks	Image
<input type="checkbox"/>	D45H11 PNP Power Transistor	3	Q9, Q10, Q11	D45H11	
<input type="checkbox"/>	PIC Microcontroller	1	U1	RAAS-8a v4.1	
<input type="checkbox"/>	40 pin IC Socket	1	U1	N/A	
<input type="checkbox"/>	LM7805 5V Linear Voltage Regulator	1	U2_5V_REG	7805 -or- LM240T5 7805 P+	
<input type="checkbox"/>	LM7812 12V Linear Voltage Regulator	1	U3_12V_REG	UTC LM7812AL	
<input type="checkbox"/>	10 Pin IDC Header	1	CN2	N/A	
<input type="checkbox"/>	14 pin IDC Header	1	CN1	N/A	
<input type="checkbox"/>	Optional USB Interface Daughterboard	1	N/A	USB to Switch Controller Bridge Module v4.1	
<input type="checkbox"/>	8 pin female header	2	H1, H2	N/A (Optional – only supplied with USB interface)	
<input type="checkbox"/>	5001 Test Ring	1	TP1	N/A	
<input type="checkbox"/>	Toggle Switch	1	N/A	N/A	
<input type="checkbox"/>	6" x 2 conductor twisted pair cable ass'y	1	N/A	N/A	
<input type="checkbox"/>	2 Conductor JST XH PCB Header	1	CN3	N/A	

<input checked="" type="checkbox"/>	Component	Qty	Circuit Designator(s)	Identifying Marks	Image
<input type="checkbox"/>	19" Alligator clip jumper wire – color may vary	1	N/A	Color will vary	
<input type="checkbox"/>	6-32 x 3/8 hex standoff	4	N/A	N/A	
<input type="checkbox"/>	6-32 x 1/4 pan head machine screw	4	N/A	N/A	
<input type="checkbox"/>	6-32 hex nut	4	N/A	N/A	



Table 2 - Controller Front Panel Parts











<input checked="" type="checkbox"/>	Component	Qty	Circuit Designator(s)	Identifying Marks	Image
<input type="checkbox"/>	Circuit Board – Controller Front Panel Board	1	N/A	Rev 3.1	
<input type="checkbox"/>	TS26 Tactile Pushbutton Switch w/LED 12mm x 12mm	8	PB1, PB2, PB3, PB4, PB5, PB6, PB7, PB8	Honyone TS26	
<input type="checkbox"/>	TS5 Tactile Pushbutton Switch 9.2mm x 9.2mm	1	PB9	Honyone	
<input type="checkbox"/>	5mm Red Light Emitting Diode	1	MANUAL	N/A	
<input type="checkbox"/>	5mm Green Light Emitting Diode	1	AUTO	N/A	



<input checked="" type="checkbox"/>	Component	Qty	Circuit Designator(s)	Identifying Marks	Image
<input type="checkbox"/>	5mm Yellow Light Emitting Diode	1	XMIT	N/A	
<input type="checkbox"/>	10 Pin IDC Header	1	PUSHBUTTONS	N/A	
<input type="checkbox"/>	14 pin IDC Header	1	LEDS	N/A	
<input type="checkbox"/>	3" x 10 conductor ribbon cable ass'y	1	N/A	N/A	
<input type="checkbox"/>	3" x 14 conductor ribbon cable ass'y	1	N/A	N/A	
<input type="checkbox"/>	4-40 x 3/8 hex standoff	2	N/A	N/A	
<input type="checkbox"/>	4-40 Hex Nut	2	N/A	N/A	
<input type="checkbox"/>	4-40 x 1/4 pan head machine screw	2	N/A	N/A	

Table 3 – Antenna Relay Box Parts

<input checked="" type="checkbox"/>	Component	Qty	Circuit Designator(s)	Identifying Marks	Image
<input type="checkbox"/>	Relay Box Enclosure	1	Only provided with kits where the enclosure was purchased as part of the kit.	Hammond 1550WE	
<input type="checkbox"/>	Circuit Board - Antenna Relay Box	1	N/A	Rev 4.0	

<input checked="" type="checkbox"/>	Component	Qty	Circuit Designator(s)	Identifying Marks	Image
<input type="checkbox"/>	SO-239 UHF Coax Connector	9	N/A	N/A	
<input type="checkbox"/>	DPDT 12V Power Relay	7	K1, K2, K3, K4, K5, K6, K7	Various models may be used. All models will have a minimum current rating of 8A per contact.	 Image is typical, color may vary
<input type="checkbox"/>	4 position Terminal Block	1	CN1	N/A	
<input type="checkbox"/>	1N4001 Diode	7	D1, D2, D3, D4, D5, D6, D7	1N4001 MDO	
<input type="checkbox"/>	100kΩ 2-Watt Metal Oxide Resistor	8	R1, R2, R3, R4, R5, R6, R7, R8	brown / black / yellow / gold (Resistor body color may vary)	
<input type="checkbox"/>	.001 μf Ceramic Disk Capacitor	7	C1, C2, C3, C4, C5, C6, C7	B STE 102K 2KV	
<input type="checkbox"/>	M5 x .80 x 10+7mm hex standoff	4	N/A	N/A	
<input type="checkbox"/>	M5 x .80 Hex Nut	4	N/A	N/A	
<input type="checkbox"/>	M5 x .80 x 8mm pan head machine screw	4	N/A	N/A	
<input type="checkbox"/>	14/16-gauge #10 ring terminal	2	N/A	N/A	

## TIPS FOR SUCCESSFUL SOLDERING

This kit has been designed to ensure relatively easy soldering. Also, the components have been placed on the circuit boards with plenty of spacing. Finally, we have chosen to use all through hole rather than surface mount components to accommodate beginning kit builders.

If this is your first attempt at building an electronics kit, or it has been a while since you've wielded a soldering iron, please refer to the following soldering tips:

1. Wear safety glasses! Consider using a small fan to blow the soldering fumes away from your nose.
2. Use a good soldering iron, or a temperature-controlled soldering station. A soldering station is preferred since it would likely come with a tip cleaning station. See *Figure 2 - Soldering Station Example* for a common example of an inexpensive soldering station. Decent soldering stations will cost about \$20 to \$30.
3. Consider using a "helping hands" station. Some versions of these also include a magnifying glass which will come in handy with some of the smaller components. Refer to *Figure 3 - "Helping Hands" Example* for an example.
4. Use the thinnest solder appropriate for the project – a diameter of around .032 works well for the type of circuit board soldering encountered on this kit.
5. 60/40 (Tin/Lead) solder is recommended for beginners since the lead content lowers the melting point of the solder which allows for much easier soldering. However, lead can be harmful to humans, so there are non-lead solders available. These non-lead types of solder have their drawbacks – the most prevalent being the high melting temperature. In the end, it is up to the individual to decide which type of solder to use.
6. Allow the soldering iron to reach its working temperature before trying to solder any components. A good working temperature for the types of components used in this kit is between 325° F and 375° F. This will also depend on the type of solder being used – please refer to the solder manufacturer's recommendations for the optimum temperature.
7. Tin the soldering iron by applying a small amount of solder directly on the iron's tip prior to touching the iron to the circuit board and component being soldered. The reason for this is that a tinned tip will transfer heat much faster, thus reducing the amount of time needed to get the solder to flow around the component lead and circuit board pad.
8. Try to structure your soldering activities by placing several components on the circuit board before picking up the soldering iron. This allows for more efficient soldering since the iron will remain tinned throughout this soldering cycle.



Figure 2 - Soldering Station Example



Figure 3 - "Helping Hands" Example

9. Apply the tip of the soldering iron evenly to both the circuit board pad and the component lead first. Then touch the solder to the lead and allow it to spread, or “flow” as it’s known in the trade. When you see the solder flow, you will know that you have a strong, well soldered joint.
10. Don't use too much solder– “the bigger the blob, the better the job” is not true here. Some have described the perfect solder joint as looking like a small Hershey’s Kiss (or a small volcano if you don’t like chocolate).
11. Clean the tip often using brass wool, or a damp sponge. Brass wool has become the preferred material since it will not lower the temperature of the soldering tip. The constant cooling and reheating of the tip can shorten its life due to contraction and expansion. However, a damp sponge will clean the tip as well.
12. Don't move the joint while it is cooling, and don't blow on it to cool it off. This can cause a “cold” solder joint which can result in a high electrical resistance between the component and the circuit board.

## CIRCUIT BOARD ASSEMBLY

Since most of this kit's assembly is performed on the three circuit boards, it's best to start there. The order of assembling the boards doesn't matter, but the order at which components are placed on each individual board does have a bearing on how easy it is to complete the board. The steps listed within each board's section have been arranged to make it as easy as possible to place and solder the component leads.

### CONTROLLER MAIN BOARD

**Note:** all soldering will be done on the underside of this circuit board.

- 1 Place the socket for the PIC microcontroller on the circuit board.



**Important!** - Ensure that the small notch on the socket is aligned with the outline printed on the circuit board.

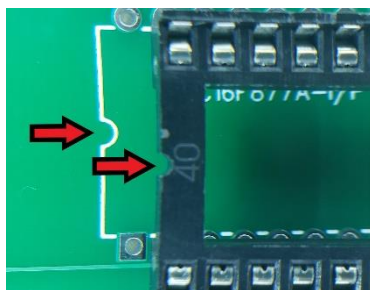

Turn the circuit board over while holding the socket in place, and carefully lay the board down on the work surface. Ensure that all 40 pins are still protruding through the circuit board. Solder one of the pins while ensuring that the socket remains flush with the circuit board. Then solder the remaining 39 pins before moving to the next step.

**Note:** Most of the components on this board all have wire leads. The following tips will help with the placement and soldering of these components:

- The following illustration shows how to “lock” the component in place by slightly bending the leads.

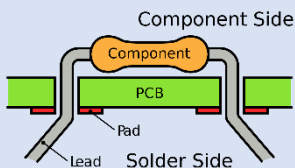

- For the resistors and diodes, use your needle nosed pliers to bend the leads on either side of the component so that they fit the holes provided for that component.
- Trim the leads using your diagonal wire cutters so they only protrude about ½ inch beyond the bottom of the circuit board.
- All components will have their component number printed as close as possible to their outline.
- Where possible, the component's value will be printed within their outline. If there is no room within the outline, then the value will be printed as close to it as possible.

- 2  Insert each of the 10 **330  $\Omega$  ¼ watt resistors (orange / orange / brown / gold)** at their respective locations: **R35, R47, R48, R49, R50, R51, R52, R53, R54, R55**. Then solder all 20 leads. Once all leads have been soldered, cut the excess leads flush with the solder joint using your diagonal cutters.
- 3  Insert each of the 14 **1 k $\Omega$  ¼ watt resistors (brown / black / red / gold)** at their respective locations: **R3, R7, R11, R16, R19, R20, R23, R24, R27, R28, R31, R33, R34, and R45**. Then solder all 28 leads. Once all leads have been soldered, cut the excess leads flush with the solder joint using your diagonal cutters.
- 4  Insert each of the 3 **3.3 k $\Omega$  ¼ watt resistors (orange / orange / red / gold)** at their respective locations: **R13, R14, R15**. Then solder all 6 leads. Once all leads have been soldered, cut the excess leads flush with the solder joint using your diagonal cutters.
- 5  Insert each of the 13 **4.7 k $\Omega$  ¼ watt resistors (yellow / violet / red / gold)** at their respective locations: **R1, R5, R9, R32, R60, R61, R62, R63, R64, R65, R66, R67, and R68**. Then solder all 26 leads. Once all leads have been soldered, cut the excess leads flush with the solder joint using your diagonal cutters.
- 6  Insert each of the 16 **10 k $\Omega$  ¼ watt resistors (brown / black / orange / gold)** at their respective locations: **R2, R4, R6, R8, R10, R12, R17, R18, R21, R22, R25, R26, R29, R30, R36, and R70**. Then solder all 32 leads. Once all leads have been soldered, cut the excess leads flush with the solder joint using your diagonal cutters.
- 7  Insert each of the 10 **0.1  $\mu$ f ceramic disk capacitors** at their respective locations: **C1, C2, C4, C5, C6, C8, C9, C10, C11, and C12**. Then solder all 20 leads. Once all leads have been soldered, cut the excess leads flush with the solder joint using your diagonal cutters.
- 8  Insert each of the 3 **0.1  $\mu$ f 1KV capacitors** at their respective locations: **C17, C18, and C19**. Then solder all 6 leads. Once all leads have been soldered, cut the excess leads flush with the solder joint using your diagonal cutters.
- 9  Insert the **0.33  $\mu$ f ceramic disk capacitor** at its location **C3**. Then solder both leads. Once they have been soldered, cut the excess leads flush with the solder joint using your diagonal cutters.
- 10  Insert each of the 4 **3V Zener diodes** at their respective locations: **D1, D2, D3, and D4**.  
**Important! - Ensure that the black stripe on each diode aligns with the stripe printed on the circuit board outline.**  
Then solder all 8 leads. Once all leads have been soldered, cut the excess leads flush with the solder joint using your diagonal cutters.
- 11  Insert one of the **1N4001 silicon diode** at its location: **D5**.  
**Important! - Ensure that the white stripe on each diode aligns with the stripe printed on the circuit board outline.**  
Then solder both leads. Once they have been soldered, cut the excess leads flush with the solder joint using your diagonal cutters.



- 12  Insert each of the 3 **red 3mm light emitting diodes (LEDs)** at their respective locations **BIT\_0, BIT\_1, and BIT\_2**.

**Important! - Ensure that the flat side of the diode aligns with the minus (-) sign printed next to the LED outline. The flat side may be hard to discern, so be advised that the shortest of the two LED leads also corresponds to the negative side of the LED.**

Then solder all 6 leads. Once all leads have been soldered, cut the excess leads flush with the solder joint using your diagonal cutters.

- 13  Insert the **test ring** at its location: **TP1**. Both leads can be soldered as one. There is no need to cut these leads as they will not protrude very far beyond the bottom of the circuit board.

- 14  Insert the **20 kΩ trimmer resistor** at its location: **R71**. Solder all 3 leads. Once all leads have been soldered, cut the excess leads flush with the solder joint using your diagonal cutters.

- 15  Insert each of the 7 **2N3904 NPN bipolar transistors** at their respective locations: **Q1, Q2, Q3, Q4, Q5, Q6, and Q7**.

**Important! - Ensure that the flat side of the transistor aligns with transistor's outline on the circuit board. Also, use as little solder as necessary when soldering each lead as the pads are very close together. Using too much solder may cause short circuits between the leads. After soldering, use a magnifying glass to inspect your work to ensure clean space between the leads.**

Note: the transistors will sit approximately 3/32" above the circuit board when properly inserted – this is expected.

Solder all 21 leads. Once all leads have been soldered, cut the excess leads flush with the solder joint using your diagonal cutters.

**Note: the next two steps cover the installation of the two 8 pin female headers that will accommodate the optional USB interface daughterboard. If you did not purchase this option, please skip to Step 18.**

- 16  Insert one of the 8 pin female headers at the location marked: **H1**.  
 Turn the circuit board over while holding the header in place, and carefully lay the board down on the work surface. Ensure that the 8 pins are still protruding through the circuit board. The weight of the board should ensure that the connector will remain in place while you solder the pins.

Solder **one of the pins** while ensuring that the connector remains flush AND perpendicular with the circuit board. Then solder the remaining 7 pins before moving to the next step.

**Important Tip: It is much easier to adjust the positioning of the 8-pin header while only one of the pins have been soldered. Make sure that the header is perpendicular to the circuit board as well as aligned with the header's white outline on the surface of the circuit board before soldering the remaining 7 pins. If need be, reheat the solder connection while manipulating the header in position with your other hand.**

- 17  Repeat step 16 for the female header at the location marked: **H2**.

**End of optional steps**

- 18  Insert the RJ-11 socket at the location marked: **J3\_TO\_RELAYS**. You will have to apply a little pressure to get the plastic pins to seat correctly – they should “pop” into place and hold the socket firmly to the circuit board. Solder the socket’s 4 pins.
- 19  Insert the male DB-9 socket at the location marked: **J2\_BAND\_DATA**. You will also have to apply a little pressure to get the metal pins to seat correctly. The pins will hold the socket in place while you solder the 9 pins as well as the 2 locking tabs.
- 20  Insert one of the **14 pin IDC headers** at the location marked: **CN1**.  
**Important! - Ensure that the notch in the connector aligns with the notch on the printed outline.**

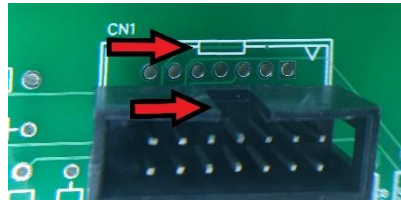

Turn the circuit board over while holding the connector in place, and carefully lay the board down on the work surface. Ensure that the 14 pins are still protruding through the circuit board. The weight of the board should ensure that the connector will remain in place while you solder the pins.

Solder one of the pins while ensuring that the connector remains flush with the circuit board. Then solder the remaining 13 pins before moving to the next step.

- 21  Insert one of the **10 pin IDC headers** at the location marked: **CN2**.  
**Important! - Ensure that the notch in the connector aligns with the notch on the printed outline.**

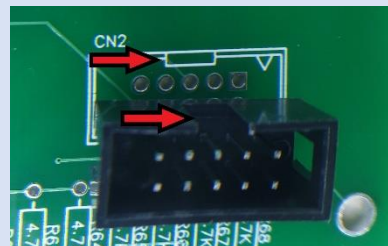

Turn the circuit board over while holding the connector in place, and carefully lay the board down on the work surface. Ensure that the 10 pins are still protruding through the circuit board. The weight of the board should ensure that the connector will remain in place while you solder the pins.

Solder one of the pins while ensuring that the connector remains flush with the circuit board. Then solder the remaining 9 pins before moving to the next step.

- 22  Attach a fuse holder on each end of the ½ Amp fuse as shown in the image to the right. Insert this assembly into the holes provided at the fuse’s location (**FH1** and **FH2**) on the circuit board and solder all four tabs.

**Note: The fuse and holders are only included in kits with main circuit board version 6.3 or later.**

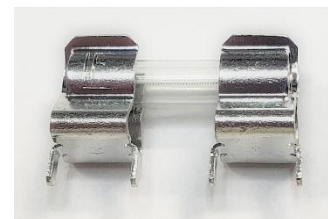

23 Insert the 12VDC power socket at the location marked: **J1\_12V\_TO\_30V**.

- Turn the circuit board over while holding the socket in place, and carefully lay the board down on the work surface. Ensure that all 3 “pins” are still protruding through the circuit board.

Solder one of the pins while ensuring that the socket remains flush with the circuit board. Then solder the remaining 2 pins before moving to the next step.

24 Insert the 2-conductor Molex PCB Header in the location marked **CN3**.

- Orient the header as shown in the image to the right. Solder both pins. No need to cut off the excess as these pins will not protrude far beyond the bottom of the circuit board.

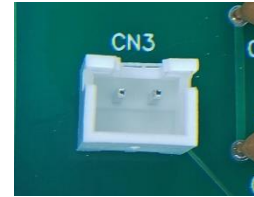

25 Solder both leads from one end of the **6” x 2 conductor twisted pair cable assembly** to the **Toggle Switch**. It doesn’t matter which color wire goes to which solder lug – just solder one wire to each lug.



26 Insert the 3 **D45H11 PNP Power Transistors** at their respective locations: **Q9, Q10, and Q11**. These components should sit about ¼ inch above the circuit board as show in the image to the right.

**Important! - Also note the orientation of the metal tabs of each transistor aligns with the double line on each component’s circuit board outline.**

Tip: slightly spread the two outer leads of each transistor prior to inserting into the holes – this will provide some friction that will help keep the case resting above the board.



Solder one of the leads first and check the case’s position – adjust as necessary by reheating the solder joint and manipulating the transistor’s position while heat is applied, and the solder is melted. Once the alignment is correct, solder the remaining 2 leads. Cut off the excess leads using your diagonal cutters.

27 Insert the **+5V linear voltage regulator** at its location: **U2\_5V\_REG**. This component should sit about ¼ inch above the circuit board as show in the figure to the right.

**Important! - Also note the orientation of the metal tab aligns with the double line on the component’s circuit board outline.**

Tip: slightly spread the two outer leads prior to inserting into the holes – this will provide some friction that will help keep the case resting above the board.

Solder one of the leads first and check the case’s position – adjust as necessary by reheating the solder joint and manipulating the regulator’s position while heat is applied, and the solder is melted. Once the alignment is correct, solder the remaining 2 leads. Cut off the excess leads using your diagonal cutters.



28 Using the same method as the previous step, insert and solder the **+12V linear voltage regulator** at its location: **U3\_12V\_REG**.

- 29  Take time to inspect all the solder connections – preferably with a magnifying glass. Look for connections that may not have enough - or too much - solder. Be especially careful when examining Q1 – Q7 to ensure that there are no solder bridges between any of the three pads associated with each transistor.

Also double-check to ensure that the correct components (especially the resistors) were placed in their respective locations.

Once this final inspection is complete, set the board aside and move to the next section: **Controller Front Panel.**

## CONTROLLER FRONT PANEL

**Note:** Except for the 2 IDC headers (LEDS and PUSHBUTTONS) all soldering will be done on the underside of this circuit board.

- 30  Insert the remaining 14 pin IDC header at the location marked: **LEDS**. Note that this component is placed on the opposite side of the circuit board from the buttons and LEDs.

**Important! - Ensure that the notch in the connector aligns with the notch on the printed outline.**

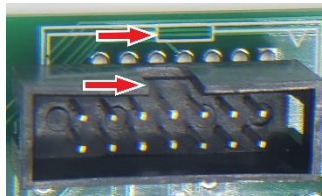

Turn the circuit board over while holding the connector in place, and carefully lay the board down on the work surface. Ensure that the 14 pins are still protruding through the circuit board. The weight of the board should ensure that the connector will remain in place while you solder the pins.

Solder one of the pins while ensuring that the connector remains flush with the circuit board. Then solder the remaining 13 pins before moving to the next step.

- 31  Insert the remaining 10 pin IDC header at the location marked: **PUSHBUTTONS**. Note that this component is placed on the opposite side of the circuit board from the buttons and LEDs.

**Important! - Ensure that the notch in the connector aligns with the notch on the printed outline.**

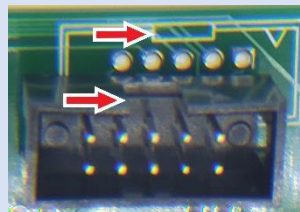

Turn the circuit board over while holding the connector in place, and carefully lay the board down on the work surface. Ensure that the 10 pins are still protruding through the circuit board. The weight of the board should ensure that the connector will remain in place while you solder the pins.

Solder one of the pins while ensuring that the connector remains flush with the circuit board. Then solder the remaining 9 pins before moving to the next step.

- 32 Insert the 8 **TS26 tactile pushbutton switches** at their respective locations: **PB1, PB2, PB3, PB4, PB5, PB6, PB7, and PB8**.



Before inserting each switch, inspect its underside and locate the positive side of the switch (+) as well as the small protruding locator “key”. The key should fit into the small hole drilled into the circuit board **above** the plus sign. Refer to the images below for clarification.

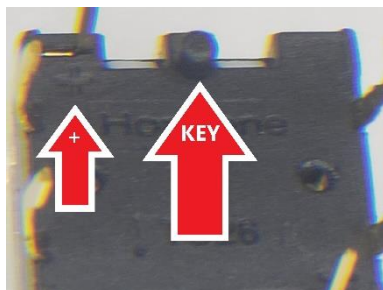

Take care that all the pins line up with the holes in the circuit board before pressing down. It will take slight pressure to seat the switches – there will be a very slight gap between the bottom of the switch and the circuit board – this is expected.

Once all the switches have been inserted, solder all 48 leads then trim them flush with the solder joint using diagonal wire cutters.

- 33 Insert the **TS5 tactile pushbutton switch** at its location: **PB9**.



Like the switches installed in the previous step, inspect its underside, and locate the positive side of the switch (+) as well as the small protruding locator “key”. The key should fit into the small hole drilled into the circuit board between the 2 top solder pads. Refer to the images below for clarification.

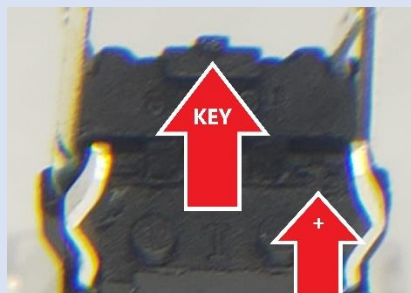

Take care that all the pins line up with the holes in the circuit board before pressing down. It will take slight pressure to seat the switches – there will be a very slight gap between the bottom of the switch and the circuit board – this is expected.

Once all the switches have been inserted, solder all 6 leads then trim them flush with the solder joint using diagonal wire cutters.

- 34  Insert the **5mm green light emitting diode (LED)** at its location: **AUTO**. Ensure that the flat (-) side of the diode aligns with the flat side of the component's outline on the circuit board. Failure to do this will result in the diode not working. Also, **position the LED so that it is 3/16" above** the circuit board.

**Tip: By spreading the leads of the LED apart slightly before inserting them into the holes, you can create enough friction from the side pressure to hold the LED at the desired height above the circuit board.**

Once the LED is in place, solder both leads then trim them flush with the solder joint using diagonal wire cutters.

- 35  Insert the **5mm red light emitting diode (LED)** at its location: **MANUAL**. Ensure that the flat (-) side of the diode aligns with the flat side of the component's outline on the circuit board. Failure to do this will result in the diode not working. Also, **position the LED so that it is 3/16" above** the circuit board.

**Tip: By spreading the leads of the LED apart slightly before inserting them into the holes, you can create enough friction from the side pressure to hold the LED at the desired height above the circuit board.**

Once the LED is in place, solder both leads then trim them flush with the solder joint using diagonal wire cutters.

- 36  Insert the **5mm yellow light emitting diode (LED)** at its location: **XMIT**. Ensure that the flat (-) side of the diode aligns with the flat side of the component's outline on the circuit board. Failure to do this will result in the diode not working. Also, **position the LED so that it is 3/16" above** the circuit board.

**Tip: By spreading the leads of the LED apart slightly before inserting them into the holes, you can create enough friction from the side pressure to hold the LED at the desired height above the circuit board.**

Once the LED is in place, solder both leads then trim them flush with the solder joint using diagonal wire cutters.

- 37  Take time to inspect all the solder connections – preferably with a magnifying glass. Look for connections that may not have enough - or too much - solder.
- Double-check to ensure that the correct colored LEDs were placed in their respective locations, and their flat sides match those of their printed outlines on the circuit board.

Once this final inspection is complete, set the board aside and move to the next section: **Antenna Relay Board**

## REMOTE ANTENNA RELAY BOARD

The following steps have been designed to make it easier to insert the individual relays while keeping the circuit board relatively level while soldering their pins. You will notice that the 7 relays will be installed using 4 successive steps for this purpose.



- 38 Insert 7 **1N4001 silicon diodes** at their locations: **D1, D2, D3, D4, D5, D6, and D7**.

**Important! - Ensure that the white stripe on each diode aligns with the stripe printed on the circuit board outline.**

Then solder both leads. Once they have been soldered, cut the excess leads flush with the solder joint using your diagonal cutters.

- 39 Insert 7 **.001  $\mu$ f Ceramic Disk Capacitors** at their locations: **C1, C2, C3, C4, C5, C6, and C7**. Then solder all 14 leads. Once all leads have been soldered, cut the excess leads flush with the solder joint using your diagonal cutters.

- 40 Insert 2 **DPDT 12V Power Relays** at locations: **K4 and K6**. Carefully turn the circuit board over while holding both relays in place with your fingertips.

Ensure that all 8 pins for each relay are protruding through the circuit board, then solder one pin for each relay to hold it flush with the circuit board. After inspecting to verify the relays remain flush, solder the remaining 14 pins.

- 41 Insert the **4-position terminal block** at its location: **CN1**. Refer to the picture below for the correct orientation:



Carefully turn the circuit board over while holding the terminal block in place with your fingertip.

Ensure that all 4 pins are protruding through the circuit board, then solder one of the pins to hold it flush with the circuit board. After inspecting to ensure that the terminal block remains flush and aligned with its outline, solder the remaining 3 pins.

Tip: You will find that placing a small weight of some kind on the circuit board will help with keeping the terminal block flush with the board while soldering the first pin.

- 42 Insert a **DPDT 12V Power Relays** at location: **K1**. Carefully turn the circuit board over while holding the relay in place with your fingertips.

Ensure that all 8 pins for the relay are protruding through the circuit board, then solder one pin for to hold it flush with the circuit board. After inspecting to verify the relay remains flush, solder the remaining 7 pins.

- 43 Insert 2 **DPDT 12V Power Relays** at locations: **K2 and K3**. Carefully turn the circuit board over while holding both relays in place with your fingertips.

Ensure that all 8 pins for each relay are protruding through the circuit board, then solder one pin for each relay to hold it flush with the circuit board. After inspecting to verify the relays remain flush, solder the remaining 14 pins.

- 44  Insert 2 **DPDT 12V Power Relays** at locations: **K5 and K7**. Carefully turn the circuit board over while holding both relays in place with your fingertips.

Ensure that all 8 pins for each relay are protruding through the circuit board, then solder one pin for each relay to hold it flush with the circuit board. After inspecting to verify the relays remain flush, solder the remaining 14 pins.

- 45  Take time to inspect all the solder connections – preferably with a magnifying glass. Look for connections that may not have enough - or too much - solder.

Once this final inspection is complete, set the board aside and proceed to the next section- ***Final Assembly***.

## FINAL ASSEMBLY

### CONTROLLER

#### FRONT PANEL

The front panel circuit board is mounted to the front panel using 2 threaded standoffs. The buttons and LEDs contained on the front side of the circuit board are designed to fit through the cutouts provided in the prepared enclosure.

- 46  Insert the male end of two 4-40 X 3/8" standoffs into the holes provided on either side of the front panel circuit board – insert it from the front side (contains the buttons and LEDs) of the circuit board and secure them with 4-40 hex nuts.
- 47  Plug one end of the 10-conductor and 14-conductor ribbon cable assemblies into their respective IDC headers on the front panel circuit board.  
Note the connector "keys" - the connectors will only fit one way, and it doesn't matter which end attaches to the circuit board.
- 48  Attach the front panel circuit board using a 4-40 x 1/4" pan head screw at each standoff.

#### MAIN BOARD

The main circuit board is mounted using 4 threaded standoffs. The three rear-mounted connectors are designed to fit through the cutouts and should end up flush with the rear panel.

- 49  Insert the male end of four 6-32 X 3/8" standoffs into the holes provided on each corner of the main circuit board – insert it from the bottom of the circuit board and secure them with 6-32 hex nuts.
- 50  If you purchased the optional USB interface, align the pins on the bottom of the daughterboard with the headers installed in steps 16 and 17 and gently press down until the pins are fully inserted into the headers. The daughterboard should be oriented as shown in the image to the right:

**Important! – Please check to make sure that the jumper next to the 20-pin microcontroller is set to short the two RAAS-8 pins as shown in the bottom image to the right:**

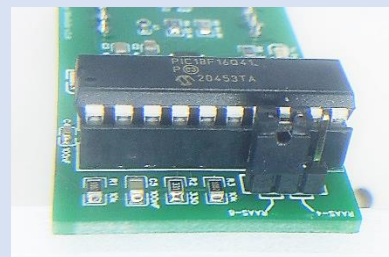

- 51 Attach the main circuit board using a 6-32 x ¼" pan head screw at each standoff.



#### POWER SWITCH AND RIBBON CABLES

- 52 Prepare the toggle switch by removing the outer nut and the lock washer and position the inner nut about halfway down the threaded collar as show in the image to the right.

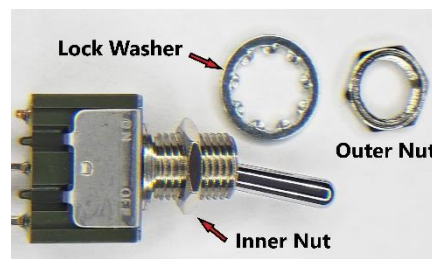

- 53 Insert the switch into the ¼" front panel hole aligned as shown in the image to the right. Make sure that the "On" position is pointing up.



Secure it by first placing the lock washer on the collar, then screw and tighten the outer nut while holding the body of the switch to prevent twisting.

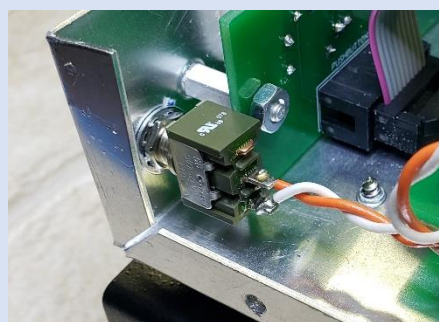

- 54 Plug the toggle switch's connector into its socket (CN3) located on the main circuit board. The connector will only fit when oriented such that the "key" fits in the "U" shaped cutout in the socket.



- 55 Plug the free ends of both the 10-conductor and 14-conductor ribbon cable assemblies into their respective IDC headers on the main circuit board.



Note the connector "keys" - the connectors will only fit one way.

Please refer to the image on the right for the proper placement of both ribbon cable assemblies.

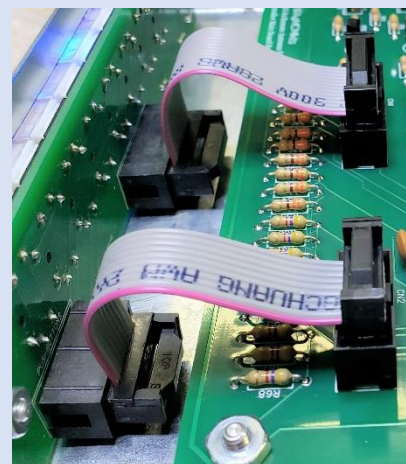

- 56 Install the 4 rubber feet that are provided with the enclosure.



## ADJUST ICOM BAND DATA VOLTAGE DIVIDER

The following steps will guide you through the adjustment of the voltage divider that will reduce the Icom band data voltage presented at the rear connector by one half. This is needed so that the resulting voltage will stay within the PIC Microcontroller's measurement window.

**Note that the PIC Microcontroller has not been installed at this point. It will be installed as the final assembly step in the next section.**

- 57  Connect one end of the **19" Alligator clip jumper wire** to the end of resistor R70 and the other end to the end of resistor R30 as shown in the image below.

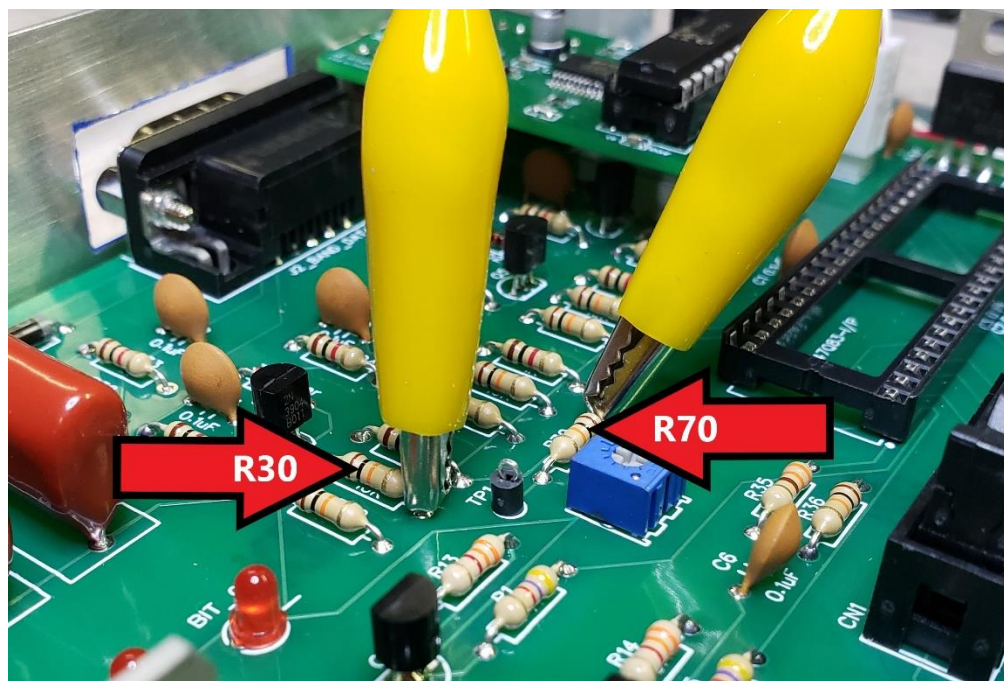

- 58  Connect the negative lead from the multimeter to the metal controller case. Connect the positive lead to the alligator clip at resistor R30. Set the multimeter so that it will measure DC voltage – approximately +5 VDC.
- 59  Plug the 12V DC Wall Power Supply into a 110V AC wall socket and the other end into the 12 VDC power jack on the rear panel of the antenna controller. Flip the front panel power switch to the “On” position.
- 60  Record the voltage reading from the multimeter. It should be +5V ( $\pm 0.05V$ ).  
 Divide your reading by 2 – **this is the target voltage**.



- 61  Move the multimeter's positive lead to TP1 and very slowly turn R71's grey adjustment "knob" using a small screwdriver so that the multimeter reads the target voltage calculated in the previous step. You may need to go back and forth on your adjustment before zeroing in on the target voltage. Refer to the image below for visual guidance.

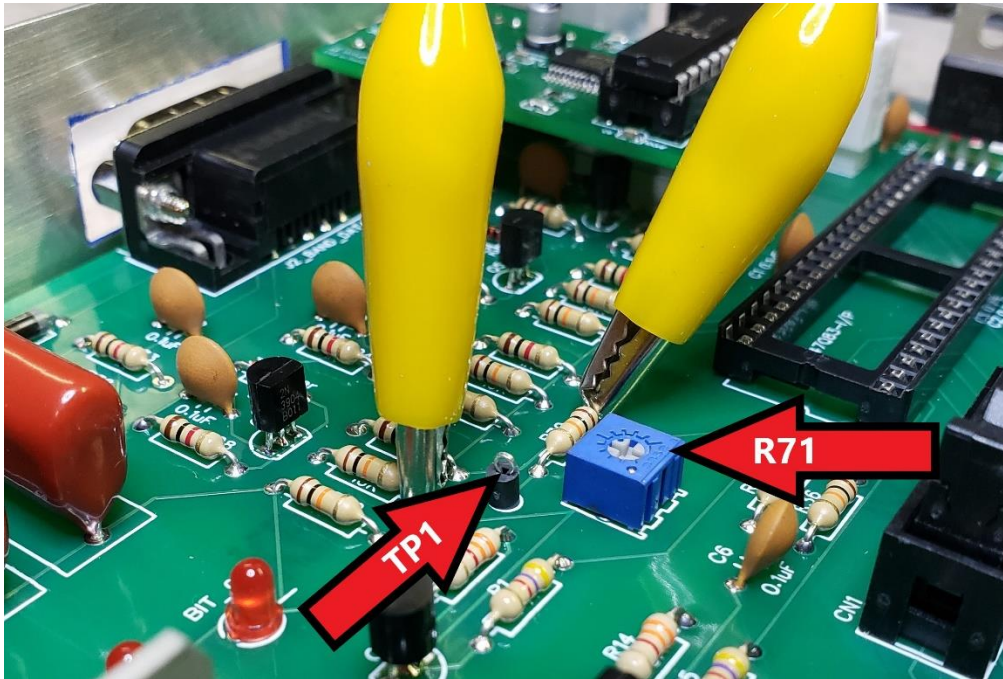

- 62  Flip the front panel power switch to the "Off" position and unplug the power supply. **Remove the multimeter test leads as well as the alligator clip jumper.**  
This concludes the voltage divider adjustment procedure. Proceed to the final controller assembly section: **Install PIC Microcontroller Chip.**

#### INSTALL PIC MICROCONTROLLER CHIP

The PIC microcontroller contains the computer code (firmware) that controls the operation of the antenna switch. It is possible to install the chip backwards, so please pay close attention to the instructions in the following installation steps.

- 63  Orient the PIC Microcontroller chip so that the small semi-circular indentation on the end of the chip is pointing in the same direction as the corresponding notch cut into the end of the socket.
- 64  The pins of a new Microcontroller chip are spread apart further than the socket's receptacles, so you will need to gently use your fingers to squeeze the two sides together until all the pins line up with their receptacle. This should be an iterative process where you squeeze the pins together a small amount and test the fit, then repeat if the fit is still not perfect.
- Once all the pins line up with their respective receptacle in the IC socket, place the chip on top of the socket ensuring that the semi-circular indentation is aligned correctly as detailed in step 63 and proceed to the next step.



- 65  **Gently** push down on the chip to ease the pins into their receptacles. If the pins have been aligned correctly, they should slide into the socket without the need for very much pressure.

**CAUTION: Be very careful not to bend any pins!**

The following image shows the installed chip in its correct alignment (note: the chip's version number will vary):



- 66  This completes the assembly of the antenna switch's controller unit.  
 The controller enclosure's cover will be installed AFTER initial testing has been completed.  
Please proceed to the next section: **Remote Antenna Relay Box**

## REMOTE ANTENNA RELAY BOX

The final assembly of the remote antenna relay box consists of installing the nine SO-239 coax connectors, then mounting the circuit board to the underside of the enclosure's cover plate. Once the circuit board has been properly fitted, the (8) 100KΩ resistors are installed.

### MOUNTING THE CIRCUIT BOARD

The relay box circuit board is mounted relay-side up on the underside of the enclosure's cover plate. Four 5.5mm holes in the circuit board will line up with four M5 x .80 x 10mm standoffs to support the circuit board. Likewise, the center conductors of the nine SO-239 Coax connectors will protrude through their respective holes in the circuit board. Once the standoffs are secured using hex nuts and the center conductors are soldered, the circuit board will be securely attached. The following steps provide details on how to mount the circuit board.

- 67  Install the (4) M5 x .80 x 10+7mm standoffs in the 5.5mm holes using (4) M5 x .80 pan head stainless steel machine screws. The standoffs should be mounted to the underside of the cover plate. **Do not tighten the screws yet.**
- 68  Install the (9) SO-239 coax connectors by inserting them through the top side of the cover plate into each of the (9) 5/8" holes. Secure them with the washer and nut provided with each connector. Once again, **do not tighten the nuts yet.**

- 69  Set the cover plate on the work surface with the underside facing up – it will be supported by the coax connectors. Align the circuit board's four 5.5mm holes with the four standoffs and attempt to push the board onto the standoffs while ensuring the center conductors of the nine coax connectors mate with their respective circuit board holes. Depending on how accurate you were with drilling the holes, you may have to "wiggle" the standoffs to get them to align with the circuit board holes. Likewise, if the coax connectors do not line up exactly, you may be able to adjust the alignment by slightly rotating each connector until its center conductor fits through the hole.

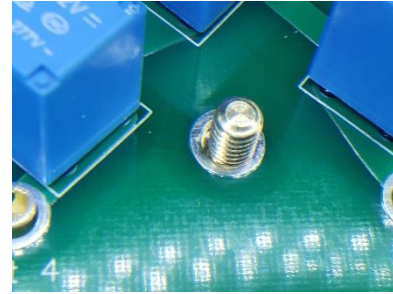

- 70  With the circuit board in place, tighten the screws securing the four standoffs so they will not change position.

Note: DO NOT use the nuts to secure the circuit board to the standoffs yet.

- 71  Note that the end of each coax connector's center pin is shaped like a semi-circle. Note the angular position of each semi-circle – this is to ensure the connectors do not rotate while tightening their nuts.



- 72  Carefully remove the circuit board and set it aside for now.

- 73  Attach a PL-259 connector to one of the coax connectors as shown in the figure to the right to provide a better grip while tightening the connector's nut. Use a pair of pliers to ensure a tight grip while tightening the nut with a 3/8" socket.

**NOTE: ensure that the connector doesn't rotate while tightening the nut, or you may not be able to fit the circuit board back in place.**

Repeat for each of the remaining 8 connectors.



- 74  Carefully re-fit the circuit board. If any of the coax connectors no longer fit into their respective holes, loosen the nut for that connector and slightly rotate it to its original position and retry the fit. Once the circuit board is fully in place and sitting flush against the shoulders of all four standoffs, proceed to the next step.

- 75  Secure the circuit board in place using an M5 x .80 hex nut at each of the 2 top-most standoffs as shown below. Tighten each nut.



- 76  Form the (2) 14/16-gauge #10 ring terminals as shown in the image to the right. Be sure that the barrel's seam is facing down before bending it upward.



- 77  Place one of the ring terminals on each of the two remaining standoffs as shown and secure them with an M5 x .80 hex nut. Tighten each nut.



- 78  Proceed to the next section for instructions on installing the (8) 100kΩ 2W Metal Oxide resistors.

## INSTALLING THE 100KΩ RESISTORS

- 79  Cut each lead of 4 of the 100KΩ 2W Metal Oxide resistors to about 7/8" and insert one end of each resistor into the barrel of the ring terminal closest to the **Ant 2** and **Ant 4** connectors as shown to the right. Arrange the 4 resistors as shown and solder them in place.

**Note:** Depending on your soldering iron's power, you may have to hold it in place for some time before the ring terminal's barrel reaches the appropriate temperature for soldering.



**Caution:** Do NOT allow the soldering iron's tip to get too close to either of the relays. Their cases are made of plastic and WILL melt easily.

- 80  Repeat the previous step for the ring terminal closest to the **Ant 6** and **Ant 8** connectors.

- 81  Carefully solder the center conductor of the Input Coax Connector as shown in the image to the right:

**Caution:** Do NOT allow the soldering iron's tip to get too close to the relay. Its case is made of plastic and WILL melt easily.



- 82  Place the free lead of the 100KΩ 2W Metal Oxide resistor closest to the Ant 4 coax connector into the connector's center conductor. Carefully solder it as well as the rest of the center conductor to the circuit board as shown in the image to the right:

**Caution:** Do NOT allow the soldering iron's tip to get too close to any of the relays. Their cases are made of plastic and WILL melt easily.



- 83  Repeat the previous step for the remaining 7 100KΩ 2W Metal Oxide resistors by placing their free leads into the center conductors of their respective antenna connectors (ANT 1, ANT 2, ANT 3, ANT 5, ANT 6, ANT 7, and ANT 8).

- 84  This completes the Antenna Relay Box's assembly. Proceed to the next section: **Testing**.

## TESTING

Before testing can begin, you will need to fabricate the cable needed to connect the controller to the remote relay box. If you intend to use the antenna switch in automatic mode, you will also need to make the band data cable to interface with your transceiver. Guidance for making these cables is contained in the antenna switch's Operation Manual.

If any of the tests listed below fail, proceed to the troubleshooting section for help.

## MANUAL MODE

Manual mode testing starts with selecting each antenna in turn and confirming that the correct antenna (and only that antenna) has been switched on at the remote relay box.

- 85  Plug the 12VDC power supply into a suitable 110V AC wall socket, then plug the other end into the controller's back panel power jack.  
 Insert the RJ-11 plug from the remote relay box into its socket on the rear panel of the antenna switch controller.
- 86  Turn the controller on by flipping the front panel toggle switch to the "On" position.  
 Carefully observe that there is no smoke or odors that would indicate any components are overheating.
- 87  Observe that the Ant 1 button lights up as the default selected antenna.  
 Also observe that the red Manual Mode LED is illuminated.
- 88  Using a multimeter set to read continuity (use the resistance mode if your multimeter doesn't have a continuity mode), connect one lead to the center conductor of the **Input** connector on the Remote Relay Box and the other lead to the center conductor of the **Ant 1** connector. There should be close to 0  $\Omega$  resistance.
- 88  While keeping the one lead on the center conductor of the Input connector, touch the other lead to the center conductor of each of the other 7 antenna connectors to ensure that there **no** continuity (or, approximately 200k $\Omega$  if using the meter's resistance mode).
- 89  On the controller's front panel, press the Ant 2 button and observe that it illuminates. Also observe that, on the controller's main board, LED bit\_0 illuminates and both LEDs bit\_1 and bit\_2 are not illuminated.
- 90  Repeat step 87 – except place the multimeter leads between the center conductors of the **Input** and **Ant 2** connectors
- 91  Repeat step 88 to confirm **no** continuity (or, approximately 200k $\Omega$  if using the meter's resistance mode) between the Input connector and the other 7 antenna connectors.

- 92 Repeat the previous 3 steps for the remaining 6 antennas. Table 4 below provides the correct status of the main board LEDs:



Table 4 - Antenna Selection Output LEDs

Selected Antenna	Bit_2	Bit_1	Bit_0
Ant 1	Off	Off	Off
Ant 2	Off	Off	On
Ant 3	Off	On	Off
Ant 4	Off	On	On
Ant 5	On	Off	Off
Ant 6	On	Off	On
Ant 7	On	On	Off
Ant 8	On	On	On

- 93 Press and release the Mode button. Observe that all 8 antenna buttons flash on and off quickly.



Also observe that the green Auto Mode LED illuminates.

- 94 This concludes the Manual Mode testing. Turn off the controller by flipping the front panel toggle switch to the "Off" position.



- 95 Install the enclosure's cover using the sheet metal screws supplied with the case.



Be careful not to tighten the screws too much as it is easy to strip the aluminum.

- 96 If you intend to use the Auto Mode, please proceed to the next section: **Auto Mode**



## AUTO MODE

Auto Mode testing consists of stepping through all the frequency bands available to your transceiver and ensuring that each band can be assigned a different antenna.

- 97 Connect the band data cable between the antenna switch controller and the appropriate interface jack on your transceiver and turn your transceiver on.



- 98 Turn on the antenna controller by flipping the front panel toggle switch to the "On" position.



Observe that the eight antenna buttons illuminate one at a time sequentially from left to right. This indicates that the controller is getting band data from the transceiver.

- 99 On your transceiver, select the lowest band available – probably 160 meters, but it doesn't matter.





100 Press and hold the Ant 1 button until it illuminates – it should take about 2 seconds.



101 On your transceiver, select the next available band. The buttons should start their sequential flashing again.



102 Press and hold the Ant 2 button until it illuminates.



103 Repeat the previous two steps for the remaining bands available on your transceiver - except press the next available button in order until all eight buttons have been assigned to a band.



Most transceivers will have more than eight bands available. Once you have assigned the eight buttons, start over with Ant 1, Ant 2, etc. until all the bands have been assigned to a button.

**Note: It's OK to assign more than one band to an antenna. In fact, this is a required feature needed for multi-band antennas.**

104 Turn the antenna switch controller off and proceed to the next section: **Remote Relay Box**



## REMOTE RELAY BOX

The remote relay box will be tested for proper operation under an RF load. You will need a dummy load as well as an SWR meter to perform these tests.

105 If your transceiver has a built in SWR meter, connect a length of 50Ω coaxial cable between the transceiver and the Input connector on the remote relay box.



If not, then connect the cable from your transceiver to the input connector on your SWR meter, then connect another length of coax from the SWR meter's output connector to the Input connector on the remote relay box.

106 Connect a dummy load rated for your transceiver's power output to the Ant 1 connector on the remote relay box.



107 **Note: The remote relay box's control cable should still be connected from the previous test sections. If not, then reconnect the cable before proceeding.**



Turn the antenna switch controller on by flipping the front panel toggle switch to the "On" position.

108 Put the antenna switch into manual mode by pressing and releasing the mode button to make the red manual mode LED illuminate.



Select Antenna 1 by pressing the Ant 1 button.

109 Set your transceiver to transmit on its highest frequency band.



Set the transceiver to a mode that will transmit a steady carrier – either use its "tune" function, or CW.

**110** Transmit a signal and check the SWR. The SWR should be better than 1.2:1



Also, if you have a band data interface cable installed, observe that the antenna controller's front panel yellow XMIT LED illuminates when the transmitter is on.

**111** Repeat the previous step for the other 7 antenna connectors:



Move the dummy load to the next antenna connector and select that antenna from the antenna controller's front panel buttons.

**112** This concludes the testing. You can now deploy the remote switch box.





## TROUBLESHOOTING

Before reviewing Table 5 below for possible solutions to your problem, please take time to inspect the following items carefully and thoroughly:

- **Solder Joints** – Bad solder joints are the single most common cause of non-working electronics projects.
- **Correct diode polarity** – Make sure that the white band is pointing in the correct direction. For LEDs, ensure that the flat side of the LED is matching the image on the circuit board.
- **Correct transistor placement** – Ensure that the transistor cases match their outlines on the circuit board. For the 2N3904 transistors, this means the flat side matches. For the D45H11 transistors, this means the “tab” matches with the double line.
- **Correct voltage regulator placement** – Ensure the “tab” matches with the double line on the circuit board outline.
- **Microcontroller is installed correctly** – Ensure that the notch is facing in the correct direction.
- **Interface cables are made correctly** – use a multimeter to ensure the cables have continuity from end to end. For the band data cable, ensure that the pins are configured according to the drawings for your specific radio. For the remote relay box cable, ensure that the RJ-11 plug has been properly crimped.

When reviewing the possible solutions in Table 5, all measurements are made between the point named in the text and chassis ground unless otherwise noted in the text.

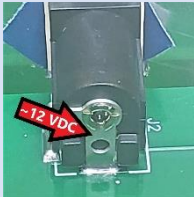
Table 5 - Troubleshooting Matrix

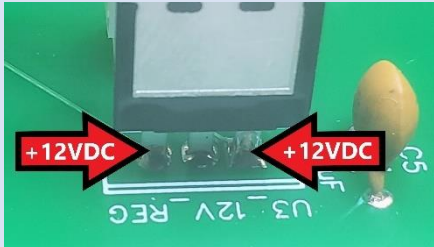
Symptom	Possible Solutions	
<p>No LEDs illuminate</p> <p>Antenna controller appears to be dead</p>	<p>Check for:</p> <ul style="list-style-type: none"> <li>~12VDC between the rear of the power jack J2 and chassis ground:</li> </ul> 	<p>If measurement is bad:</p> <ul style="list-style-type: none"> <li>Not plugged in or no power at wall outlet</li> <li>Faulty wall adapter</li> </ul>
	<ul style="list-style-type: none"> <li>~5VDC between the output of the 5V linear regulator and chassis ground.</li> </ul>  <ul style="list-style-type: none"> <li>If incorrect voltage, check for 12VDC on the input pin.</li> </ul>	<ul style="list-style-type: none"> <li>If there is not 12V on the input pin, then there is a faulty solder joint.</li> <li>If there is 12V on the input pin, then U2 (LM7805) is faulty.</li> </ul>
	<ul style="list-style-type: none"> <li>~12VDC between the output of the 12V linear regulator and chassis ground:</li> </ul>  <ul style="list-style-type: none"> <li>If incorrect voltage, check for 12VDC on the input pin.</li> </ul>	<ul style="list-style-type: none"> <li>If there is not 12V on the input pin, then there is a faulty solder joint.</li> <li>If there is 12V on the input pin, then U3 (LM7812) is faulty.</li> </ul>

Symptom	Possible Solutions	
<p>No LEDs illuminate</p> <p>Antenna controller appears to be dead (continued)</p>	<p>Check for:</p> <ul style="list-style-type: none"> <li>• Check to see if the microcontroller is getting power: 5 vdc between pin 11 and chassis ground.</li> <li>• Check to see if the microcontroller is running by observing the chip's clock on pin 13 of U1 with an oscilloscope. It should be an 8 MHz sine wave.</li> </ul>	<p>If measurement is bad:</p> <ul style="list-style-type: none"> <li>• Bad solder joint in the circuit path between the 5V linear regulator (U2) and pin 11 of the microcontroller.</li> <li>• Microcontroller in backwards</li> <li>• Bad solder connection on the chip socket</li> <li>• Bad 8MHz crystal</li> <li>• Bad Microcontroller</li> </ul>
<p>The wrong antenna is selected at the remote relay box.</p>	<p>Check for:</p> <ul style="list-style-type: none"> <li>• Are the bit_0, bit_1, and bit_2 LEDs showing the correct pattern as detailed in <b>Table 4 - Antenna Selection Output LEDs?</b></li> </ul> <div data-bbox="513 947 992 1178" data-label="Image"> </div> <p>This figure shows the LEDs lit for antenna 6.</p> <ul style="list-style-type: none"> <li>• On the remote relay box circuit board, check the voltages at the terminal block. There should be 12 vdc at the each of the three terminals (A, B, C) to match the bit_0, bit_1, and bit_2 from the above observation.</li> </ul>	<p>If measurement is bad:</p> <ul style="list-style-type: none"> <li>• If bit_0 should be illuminated, but isn't, possible faulty Q1 and/or Q9.</li> <li>• If bit_1 should be illuminated, but isn't, possible faulty Q2 and/or Q10.</li> <li>• If bit_2 should be illuminated, but isn't, possible faulty Q3 and/or Q11.</li> <li>• RJ-11 plug made incorrectly</li> <li>• Cable wires transposed.</li> </ul>

Symptom	Possible Solutions	
<p>The mode doesn't change when pushing the front panel mode button.</p>	<p>Check for:</p> <ul style="list-style-type: none"> <li>+5 vdc on pin 1 of the mode switch:</li> </ul> 	<p>If measurement is bad:</p> <ul style="list-style-type: none"> <li>Bad solder joint in the circuit path between the 5V linear regulator (U2) and pin 1 of the mode switch.</li> </ul>
	<ul style="list-style-type: none"> <li>+5 vdc on U1 pin 37 when the mode button is depressed.</li> </ul>	<ul style="list-style-type: none"> <li>Bad solder joint in the circuit path between the mode switch and U1 pin 37.</li> </ul>
<p>When auto mode is selected, the front panel antenna buttons all flash quickly at the same time.</p>	<p><b><u>Non-Icom Transceivers:</u></b></p> <p>Check for:</p> <ul style="list-style-type: none"> <li>Check for 0 vdc on at least one of the following pins on the microcontroller: pin33, pin34, pin35, or pin36.</li> </ul>	
	<p><b><u>Icom Transceivers:</u></b></p> <p>Check for:</p> <ul style="list-style-type: none"> <li>Check for a voltage between 1.0 vdc and 8 vdc on the R70 lead furthest from TP1.</li> </ul>	
	<p>If measurement is bad:</p> <ul style="list-style-type: none"> <li>Radio is not turned on</li> <li>Band data interface cable is faulty on one or more of these pins: 2, 3, 4, or 5</li> </ul>	
	<p>If measurement is bad:</p> <ul style="list-style-type: none"> <li>Radio is not on</li> <li>Band data interface cable is faulty on pin 6</li> </ul>	



Symptom	Possible Solutions	
A band for which I haven't assigned an antenna already has one assigned.	<p><b><u>Non-Icom Transceivers:</u></b></p> <p>Check for:</p>	<p>If measurement is bad:</p>
	<ul style="list-style-type: none"> <li>Place a jumper between the R32 lead furthest from the rear of the controller and the R16 lead closest to the rear of the controller. Confirm 0 vdc on pin 33 of the microcontroller.</li> </ul>	<ul style="list-style-type: none"> <li>Poor solder joint in the BCD_A circuit path</li> <li>Faulty Q4</li> </ul>
	<ul style="list-style-type: none"> <li>Place a jumper between the R32 lead furthest from the rear of the controller and the R20 lead closest to the rear of the controller. Confirm 0 vdc on pin 34 of the microcontroller.</li> </ul>	<ul style="list-style-type: none"> <li>Poor solder joint in the BCD_B circuit path</li> <li>Faulty Q5</li> </ul>
	<ul style="list-style-type: none"> <li>Place a jumper between the R32 lead furthest from the rear of the controller and the R24 lead closest to the rear of the controller. Confirm 0 vdc on pin 35 of the microcontroller.</li> </ul>	<ul style="list-style-type: none"> <li>Poor solder joint in the BCD_C circuit path</li> <li>Faulty Q6</li> </ul>
	<ul style="list-style-type: none"> <li>Place a jumper between the R32 lead furthest from the rear of the controller and the R28 lead closest to the rear of the controller. Confirm 0 vdc on pin 36 of the microcontroller.</li> </ul>	<ul style="list-style-type: none"> <li>Poor solder joint in the BCD_D circuit path</li> <li>Faulty Q7</li> </ul>
	<p><b><u>Icom Transceivers:</u></b></p> <p>Check for:</p>	
<ul style="list-style-type: none"> <li>Step through the transceiver's bands one at a time and confirm the following voltages at TP1:                             <ul style="list-style-type: none"> <li>160 m: <math>\geq 3.26</math> vdc</li> <li>80 m: <math>\geq 2.76</math> vdc; <math>\leq 3.25</math> vdc</li> <li>40 m: <math>\geq 2.26</math> vdc; <math>\leq 2.75</math> vdc</li> <li>30 m: <math>\geq 0.5</math> vdc; <math>&lt; 0.6</math> vdc</li> <li>20 m: <math>\geq 1.76</math> vdc; <math>\leq 2.25</math> vdc</li> <li>17/15 m: <math>\geq 1.26</math> vdc <math>\leq 1.75</math> vdc</li> <li>12/10 m: <math>\geq 1.0</math> vdc; <math>\leq 1.25</math> vdc</li> <li>6 m: <math>\geq 0.6</math> vdc; <math>&lt; 1.0</math> vdc</li> </ul> </li> </ul>	<ul style="list-style-type: none"> <li>Mis-adjusted R71</li> </ul>	
The XMIT LED illuminates when the radio is <b><u>NOT</u></b> transmitting.	<p>Check for:</p> <ul style="list-style-type: none"> <li>~5 vdc on pin 9 of the microcontroller</li> </ul>	<p>If measurement is bad:</p> <ul style="list-style-type: none"> <li>Poor solder joint on either R32 or R33</li> </ul>

Symptom	Possible Solutions	
The XMIT LED doesn't illuminate when the radio is transmitting.	Check for:	If measurement is bad:
	<ul style="list-style-type: none"> <li>• Check for ~4.7 vdc on the cathode (banded end) of diode D5 while <b>NOT</b> transmitting.</li> </ul>	<ul style="list-style-type: none"> <li>• Faulty D5</li> </ul>
<ul style="list-style-type: none"> <li>• Check for 0 vdc on the cathode of diode D5 while transmitting.</li> </ul>	<ul style="list-style-type: none"> <li>• Faulty band data interface cable pin 7.</li> </ul>	

SCHEMATIC DIAGRAMS

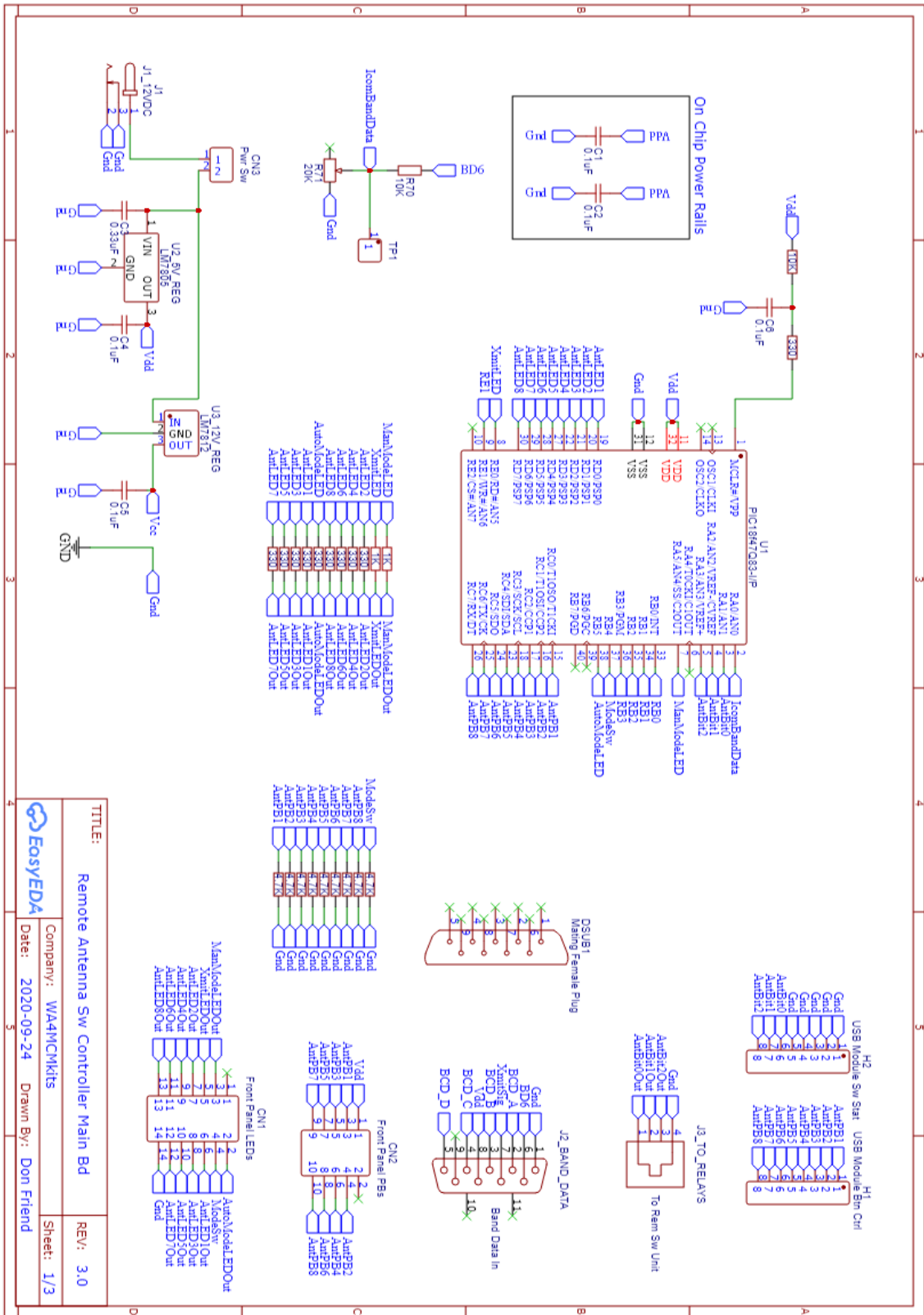

TITLE:		Remote Antenna Sw Controller Main Bd
Company:		WA4MCMkits
Date:		2020-09-24
Drawn By:		Don Friend
REV:		3.0
Sheet:		1/3

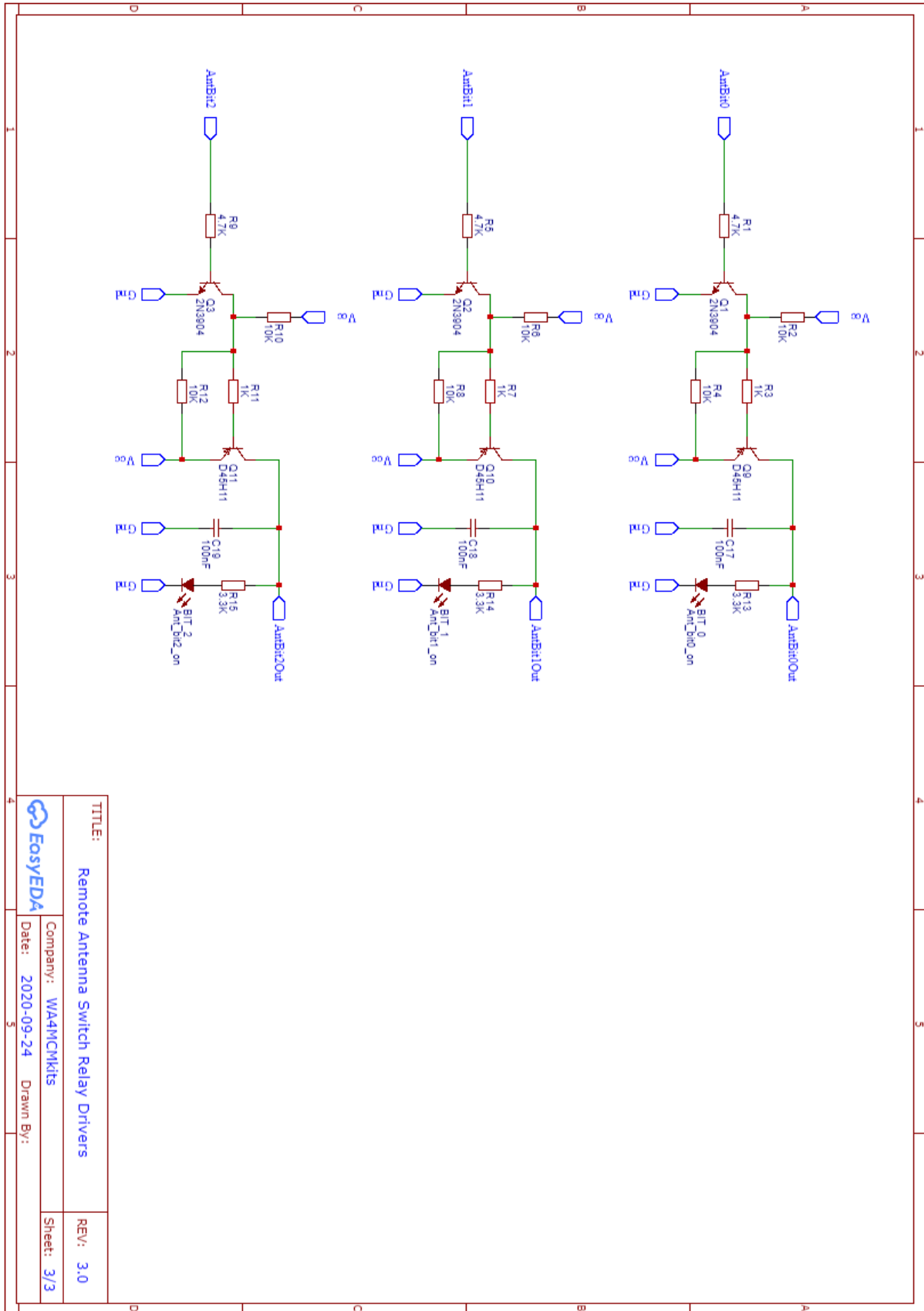

TITLE: Remote Antenna Switch Relay Drivers		REV: 3.0
Company: WA4MCMkits		Sheet: 3/3
Date: 2020-09-24	Drawn By:	

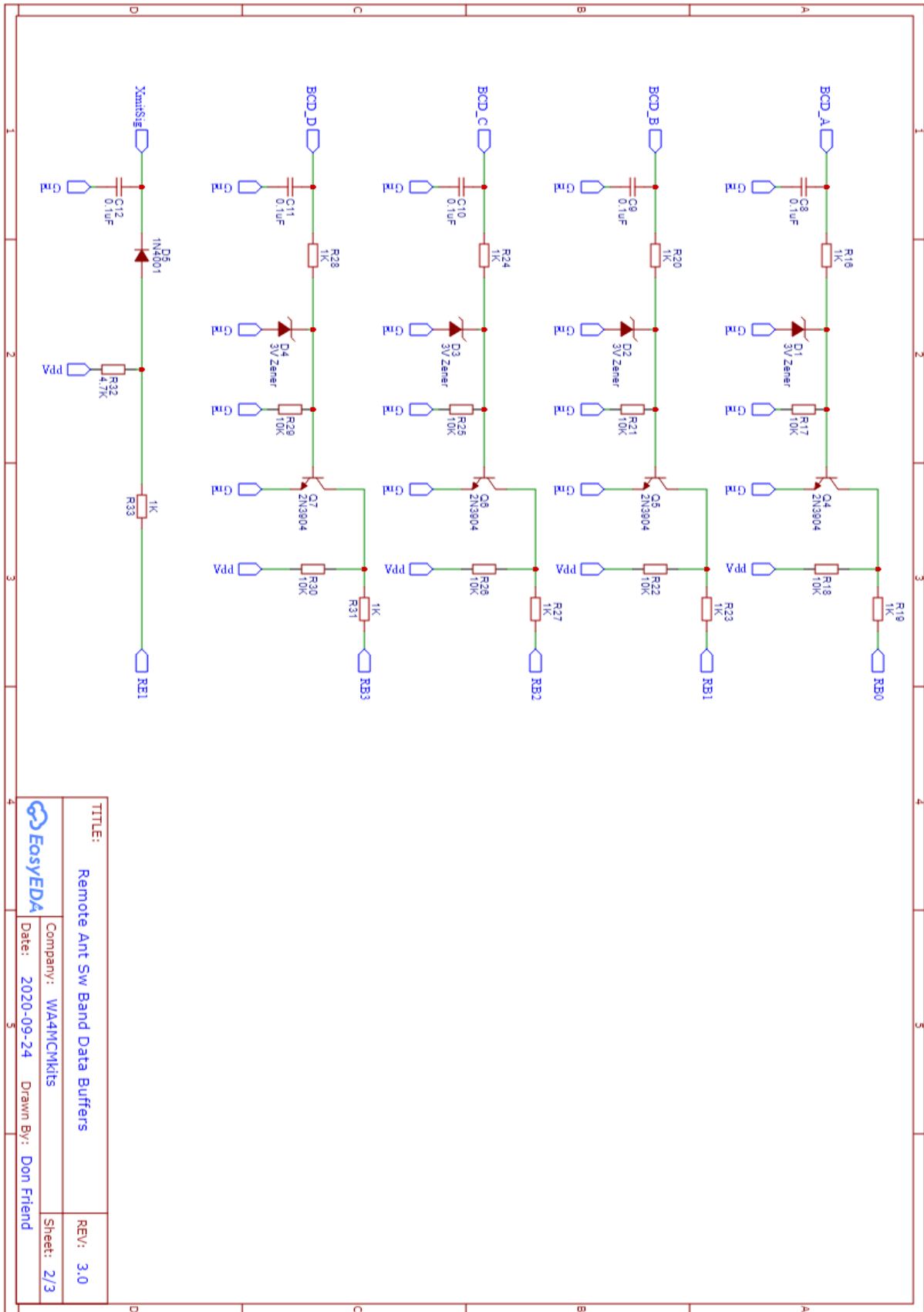

TITLE:		Remote Ant Sw Band Data Buffers	REV: 3.0
Company:		WA4MCMkits	Sheet: 2/3
Date:	2020-09-24	Drawn By:	Don Friend

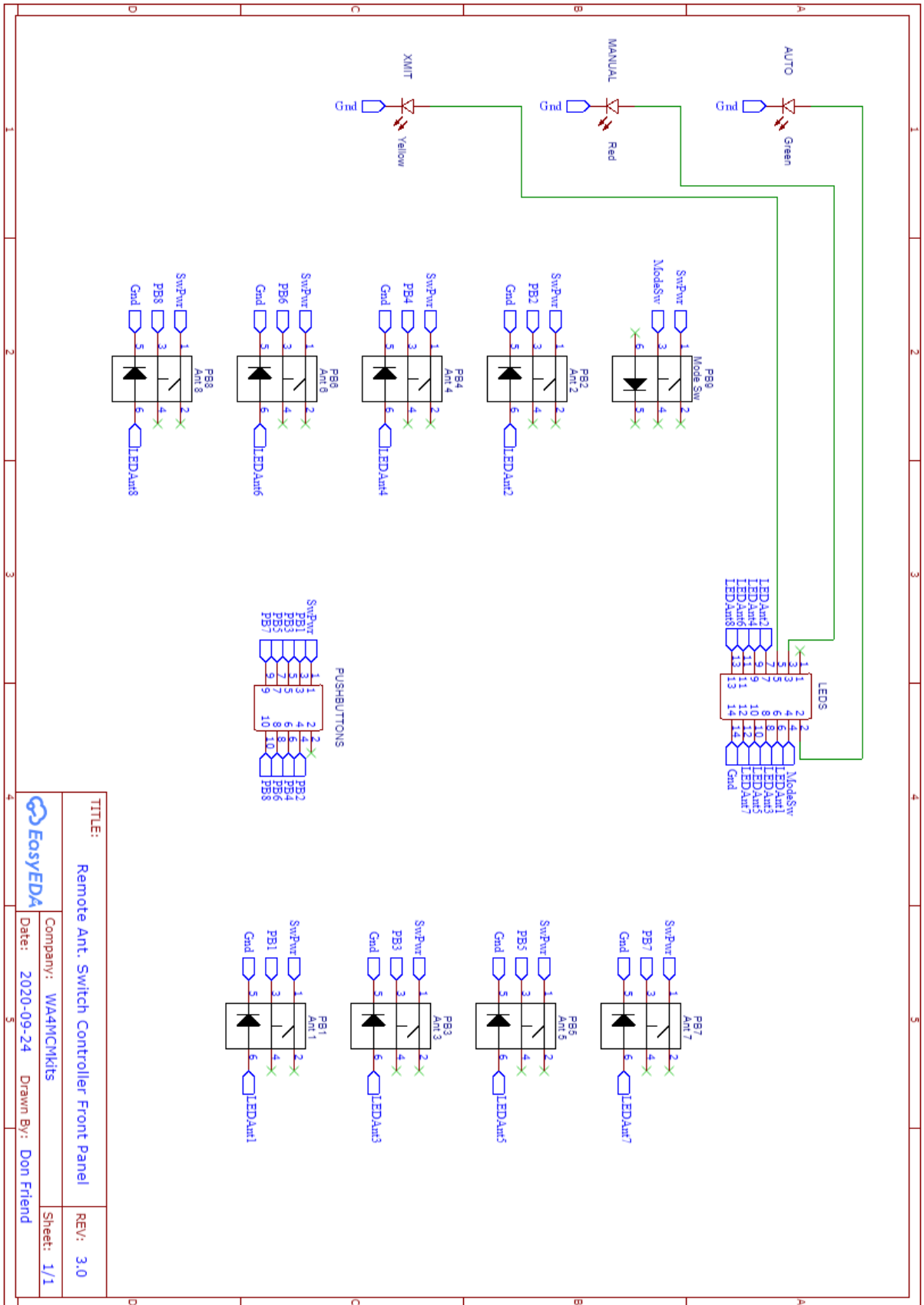

TITLE:	Remote Ant. Switch Controller Front Panel	REV:	3.0
Company:	WA4MCMkits	Sheet:	1/1
Date:	2020-09-24	Drawn By:	Don Friend



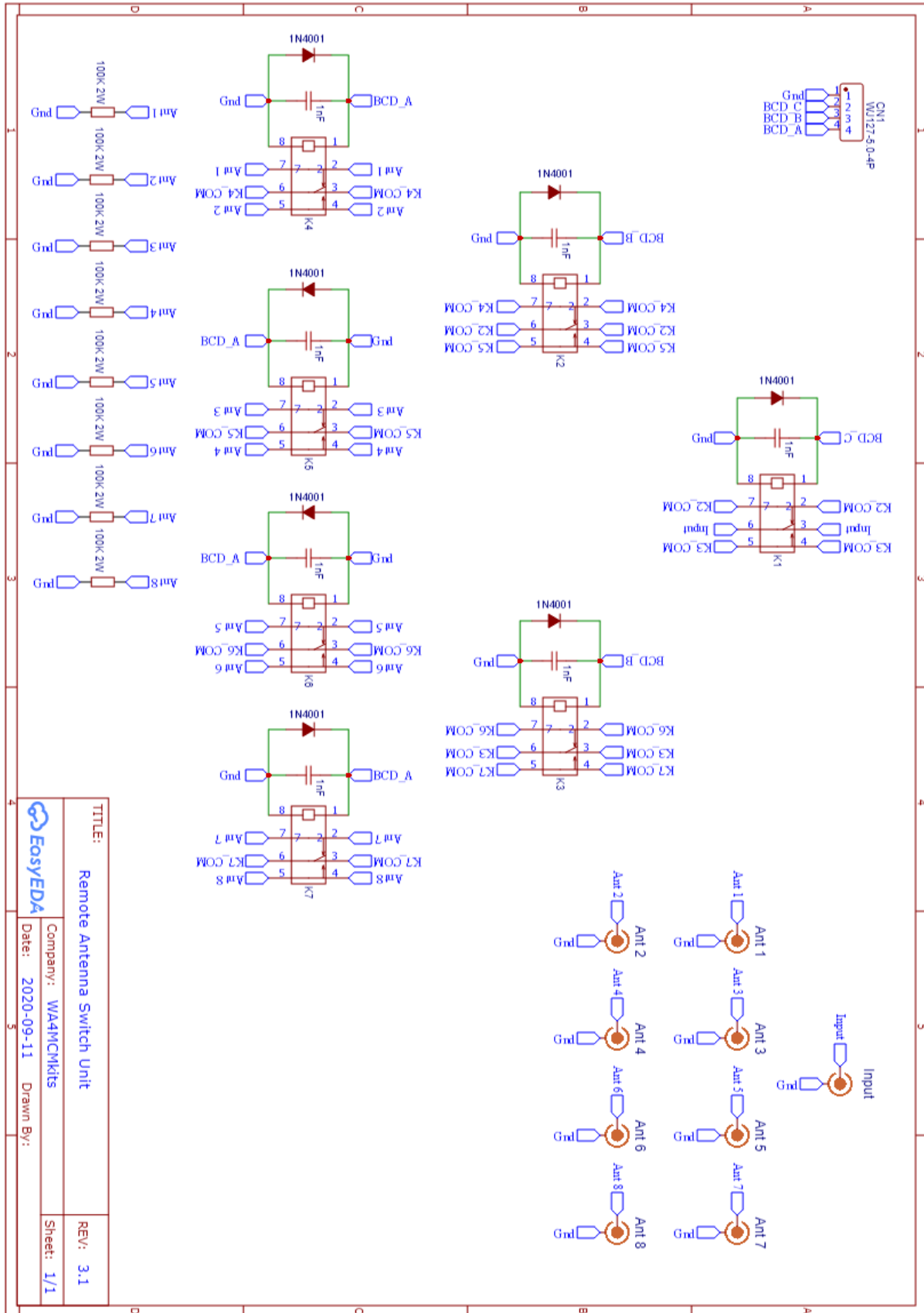

		TITLE: Remote Antenna Switch Unit
Company: WA4MCMkits	Date: 2020-09-11	REV: 3.1
Drawn By:	Sheet: 1/1	

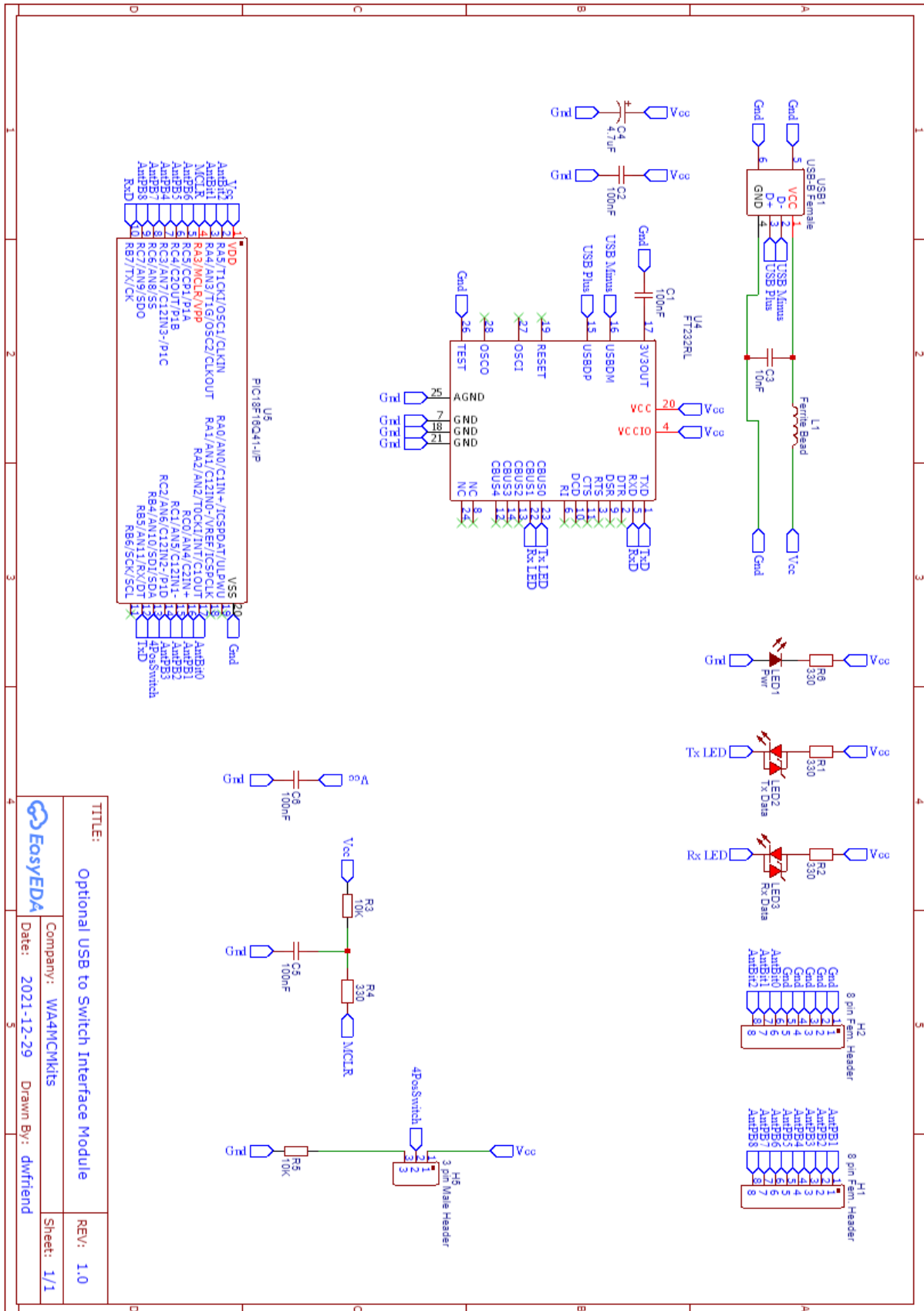

TITLE: Optional USB to Switch Interface Module

Company: WA4MCMkits

Date: 2021-12-29

Drawn By: dwfriend

REV: 1.0

Sheet: 1/1