



# OPERATION MANUAL - RAAS-4a Remote Automatic Antenna Switch

## Revision History

Revision Number	Date	Description	Notes
1.1	2/21/2022	<ul style="list-style-type: none"> <li>Modified instructions for installing optional USB virtual ComPort drivers from FTDI.</li> <li>Added a paragraph and tips for proper placement of the Bias-T box so that it would have no problem sending the control signals to the remote relay box.</li> </ul>	
1.2	3/4/2022	<ul style="list-style-type: none"> <li>Modified the <i>Windows Computer Interface (optional)</i> section to accommodate a design change which replaced the FTDI chip with the Silicon Labs chip as the USB to UART bridge.</li> </ul>	
1.3	2/17/2023	<ul style="list-style-type: none"> <li>Added new communications protocol for controlling the switch's mode via the USB interface.</li> </ul>	Thanks to Kyle – AA0Z for his idea and support during the development of this new feature.
1.4	3/10/2023	<ul style="list-style-type: none"> <li>Added instructions for obtaining band data as well as the transmit signal from Flex radios</li> </ul>	Thanks goes to W4WU (Richard Cash) for his research and providing his results.
1.5	4/18/2023	<ul style="list-style-type: none"> <li>Fixed references to supply voltage where the old 9VAC voltage still remained. Changed to 12VAC in all locations.</li> </ul>	
1.6	7/2/2023	<ul style="list-style-type: none"> <li>Refined the Flex Radio 6000 Series band data section to reflect input from the field. Added a pinout table to clarify how to connect the switch-end DB-9 connector to the C232HM cable.</li> </ul>	Thanks goes to M0MDS (Mike Field) for his invaluable research and input.
1.7	8/28/2023	<ul style="list-style-type: none"> <li>Added band data pin-out diagram for the Yaesu FTdx-101 series of radios.</li> </ul>	
1.8	12/05/2023	<ul style="list-style-type: none"> <li>Fixed inaccurate switch box dimensions</li> </ul>	
1.9	1/12/2024	<ul style="list-style-type: none"> <li>Added some guidance to the appendices for mounting the remote relay box.</li> </ul>	

**CONTENTS**

Introduction .....	4
Features .....	4
Specifications .....	4
Overview .....	5
Band Data information .....	5
Front Panel .....	5
Rear Panel .....	6
external bias-t box .....	6
Installation .....	8
Power Connection .....	8
Connecting to the bias-T and Relay Box .....	8
Transceiver band data Interface .....	8
Interfacing with Icom radios .....	9
Interfacing with Yaesu radios .....	10
Interfacing with Elecraft radios .....	12
Interfacing with Flex Radios .....	12
Windows Computer Interface (optional) .....	13
Virtual Serial Port Driver Installation .....	13
Antenna Switch Configuration .....	14
PC to/From Switch Communication Protocol .....	14
Supplied Windows Remote Control Application .....	15
Integrating With REmoteHams Server .....	16
Antenna Switch Operation .....	17
antenna selection signal description .....	17
Manual Mode .....	17
Automatic Mode .....	17
Assigning Antennas .....	18
Unassigning Antennas .....	18
Appendices .....	19
Troubleshooting .....	19
Remote Relay Box Mounting Guidance .....	21
Mounting Brackets .....	21

Zip Ties .....22

Stainless Steel Hose Clamps .....22

Weatherproof Enclosures .....22

Under the Eaves.....22

## INTRODUCTION

Thank you for purchasing this remote antenna switch kit. Every effort has been taken to design a product that will provide years of service and will enhance your ability to select the antenna you need for any situation.

I made this a kit in an effort to bring back some of the kit building nostalgia that was prevalent in the early days of Amateur Radio as well as add to the growing Maker Movement. A decision was made to use all through-hole components on the circuit boards to make the kit attractive to beginners. To keep the cost down, inexpensive off-the-shelf enclosures are used which also allows for the builder to acquire new metalworking skills.

73's,

Don – WA4MCM

## FEATURES

- **Easy to Operate** – This antenna switch can be as easy to operate as simply pressing a button to select an antenna.
- **Automatic Antenna Selection** - If your transceiver provides band data, it can easily be programmed by the operator to automatically select an antenna when a new band is selected. The same antenna can be assigned to multiple bands.
- **Compatibility** – The automatic antenna selection feature relies on band data being supplied by the transceiver. It can utilize one of two types of band data: 4-line BCD (Yaesu and Elecraft), and voltage level (Icom). Unfortunately, Kenwood radios don't specifically output band data, but instead rely on the user to query the CAT port. However, there are commercially available band data decoders that will interface with Kenwood rigs and provide the necessary inputs to this antenna switch.
- **Transmitter Protection** – The switch will accept a transmit signal from the transceiver and lock out the ability to change antennas while transmitting.
- **No Separate Control Line Required** – The switch sends the control signal over the coaxial feedline using a bias-T connection.
- **Can Interface with a Windows PC (optional)** – With the optional USB interface board, the switch can be remotely controlled via a Windows PC. We have also collaborated with the folks at RemoteHams.com to integrate the switch with their remote control software.
- **Handles Up to 1500 Watts** – The switch will handle up to 1500 watts into a 50Ω load.
- **Low SWR** – the SWR is less than 1.2:1 for the 160 through 6-meter bands; less than 1.5:1 for the 2-meter band.

## SPECIFICATIONS

- Input Voltage: 12 VAC @ 400mA (a 12VAC .5A wall adapter is provided)
- Relay Output Voltage: 12 VAC
- Relay Output Format: depending on the antenna selected: positive rectified 12VAC, negative rectified 12VAC, 12VAC
- Number of Antennas: up to 4 antennas (antenna #1 is selected by default when no power applied)

- Band Data Input: 4-line BCD (binary “0”: 0V DC; binary “1”: +5V DC), or voltage (0V to +8V DC)
- Transmit Signal Input: input line should be sent to ground by the radio when transmitting
- Controller Dimensions: 7 ¼” W x 6 ⅛” D x 1 ½” H
- Relay Box Dimensions: 4 ½” W x 3 ½” D x 2 ¼” H

## OVERVIEW

### BAND DATA INFORMATION

This switch can operate in one of two modes: Manual and Automatic.

In Manual Mode, an antenna is selected by simply pressing one of the 4 antenna buttons. The antenna will remain selected until the operator pushes a different button or changes the mode to Automatic.

In Automatic mode, depending on the transceiver manufacturer, the switch will read either the 4-line BCD pattern (e.g., Yaesu, Elecraft) or the band data voltage (e.g., Icom) presented at back panel connector. The operator can easily program which antenna should be selected for the BCD pattern or voltage level associated with the currently selected band. It doesn’t matter what the pattern or voltage level is because the operator is free to assign ANY of the 8 available antennas to any pattern or voltage – even to multiple patterns.

The following list provides details about how the different manufacturers provide band data:

- **Icom** – Icom transceivers provide band data from an accessory jack on the back of the transceiver. On some rigs, this is a 13-pin DIN connector. On others, it may be a 7-pin DIN connector. In either case, a voltage between 0V and 8V DC is provided to represent the currently selected operating band.

**A note about Icom Band Data:** Icom has chosen to use the same voltage level for the 10- and 12-meter bands (2V – 2.5V) and the same voltage level for the 15- and 17-meter bands (3V – 3.5V). You will not be able to assign a different antenna to either of these two band pairs.

- **Yaesu, Elecraft, and some others** – These manufacturers provide band data in the form of a 4-bit BCD word that corresponds to each operating band supported by the radio. Each bit can be either a “1” (+5VDC) or a “0” (0VDC).

If your transceiver is not listed above, check your radio’s instruction manual to see if it provides band data using one of these two methods.

### FRONT PANEL

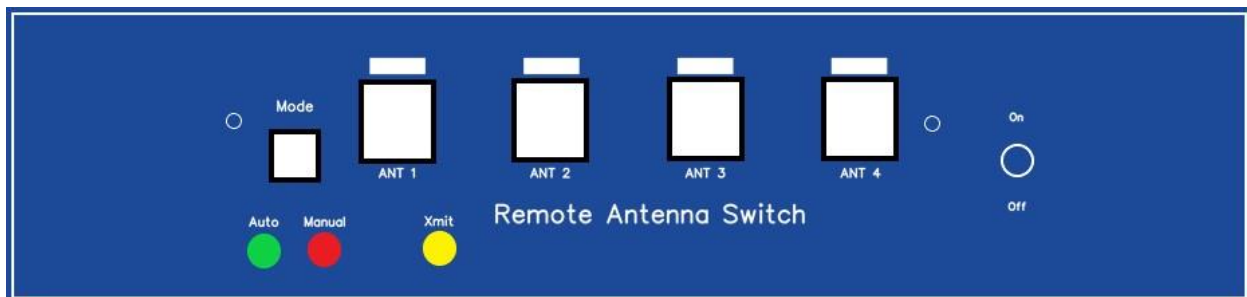

- On / Off Switch: When switched to the “On” position, provides power to the Remote Antenna Switch controller.

- **Mode Pushbutton:** Toggles between Manual and Automatic Mode.
- **Auto LED:** Indicates that the controller is in automatic mode and will select the antenna based on the band data received from the transceiver.
- **Manual LED:** Indicates that the controller is in manual mode and will select the antenna based on the operator's button selection.
- **Xmit LED:** When lit, the radio is transmitting, and all antenna selection functions as well as the Mode switch are locked out.
- **Antenna 1 – 4 Pushbuttons** Provide the means for either selecting an antenna while in manual mode or assigning an antenna to a particular band data pattern or voltage while in automatic mode. The buttons will also illuminate to indicate the currently selected antenna.

## REAR PANEL

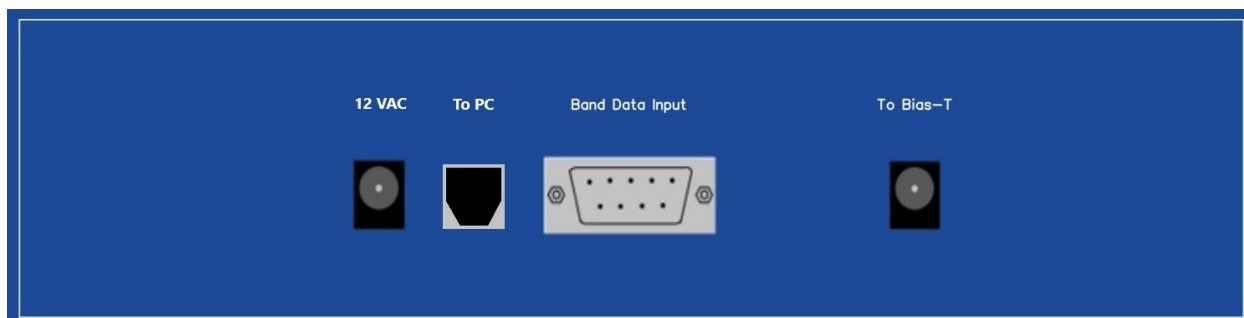

- **12 VAC Jack:** Accepts the power plug from the 12 VAC wall adapter. Will accept any standard 5.5mm x 2.1mm 12 VAC power plug.
- **Band Data Input:** Male DB-9 receptacle for plugging in an interface cable containing the band data and transmit signal lines.
- **To Bias-T:** This is a standard 5.5mm x 2.1mm power receptacle for plugging in the cable going to the external bias-T box.

## EXTERNAL BIAS-T BOX

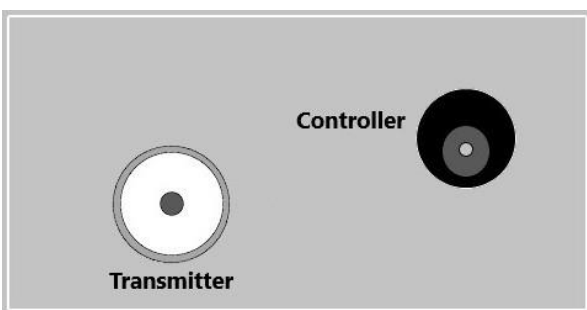

Bias-T Side One

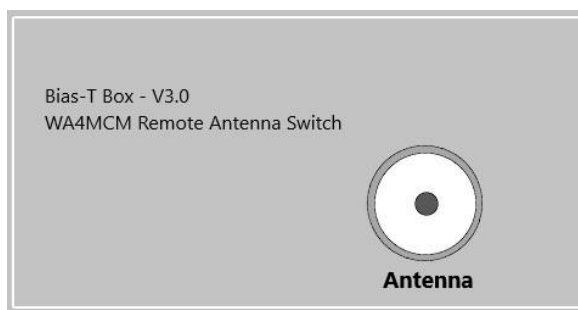

Bias-T Side Two

- **Transmitter:** This is a standard UHF (SO-239) female connector which receives the 50Ω coaxial cable jumper from the back of the transmitter/transceiver or linear amplifier.
- **Controller:** This is a standard 5.5mm x 2.1mm power receptacle for plugging in the cable coming from the antenna switch controller.

- **Antenna:** This is a standard UHF (SO-239) female connector which connects to the main coaxial feedline that goes out to the remote relay box's input connector.



## INSTALLATION

### POWER CONNECTION

The remote antenna switch kit comes with a 12 VAC wall adapter whose plug will fit the power socket. However, the unit will accept any standard 12 VAC wall adapter with a 5.5mm x 2.1mm plug.

### CONNECTING TO THE BIAS-T AND RELAY BOX

Please refer to the following drawing for guidance on connecting the antenna switch controller to the bias-T box as well as connecting the coaxial feedline between the back of the RF source (transceiver or linear amp) and the remote relay box.

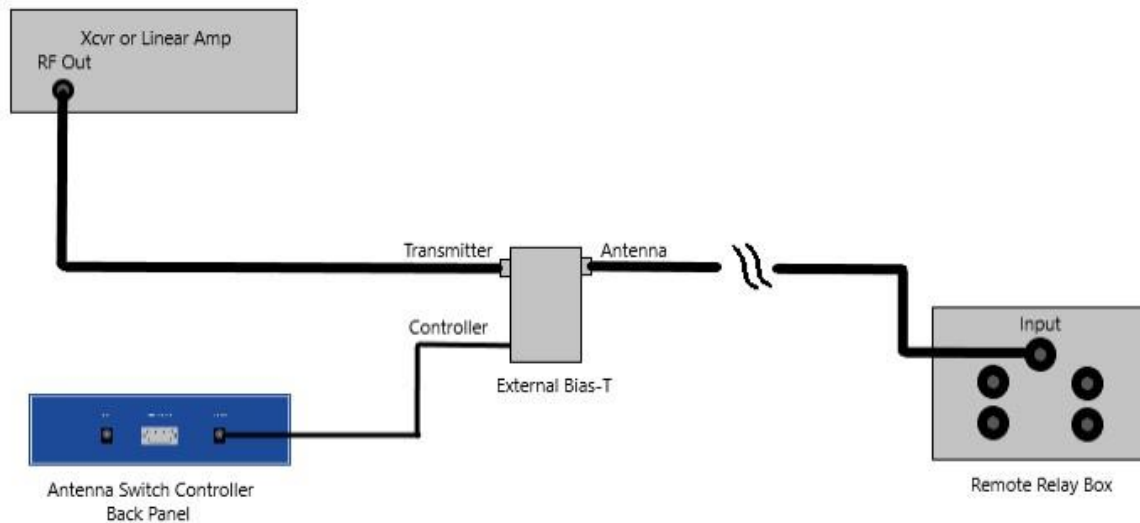

The Bias-T box injects the relay control voltage onto the coaxial cable for transmission to the remote relay box where it is “picked off”, then rectified and filtered before energizing the appropriate relay(s). The control voltages used are various forms of a 60Hz sine wave (or 50Hz if that’s your local supply standard), so it is imperative that there are no impediments in the feedline between the Bias-T box and the remote relay box.

Please refer to the following list of devices that may prevent the proper operation of this switch:

- Most linear amplifiers will not pass the control voltage while in operation due to their output stages and tank circuits. The Bias-T box **MUST** be placed after any linear amplifiers. Don’t worry, it has been tested and can handle full legal power.
- Many lightning arrestors will not allow the control signal to pass. Check your arrestor’s data sheet to confirm whether it will pass the Bias-T voltage, or not.
- Antenna tuners may also limit the operation of the Bias-T depending on their configuration. It may be necessary to place the Bias-T box after any antenna tuners.

### TRANSCEIVER BAND DATA INTERFACE

As noted earlier in this manual, the antenna switch uses two types of data from the transceiver:

- Band Data – either via a 4-line BCD word, or a “stepped” voltage level between 0V and 8V DC
- Transmit Signal – a single line that is sent to ground by the radio when the transmitter is keyed. This line will carry about 1mA of current when the transmitter is keyed.

Depending on the specific radio manufacturer and model, the data may be provided on a back-panel jack used for connecting a linear amplifier, or some other accessory jack. These will usually be some form of a multi-pin DIN connector. Please refer to your radio’s user manual for details. The antenna switch accepts the data via the Band Data Input connector on the back of the controller unit. This is a standard male DB-9 connector. Table 1 lists each pin’s function for this connector.

Table 1 - Band Data Pinout

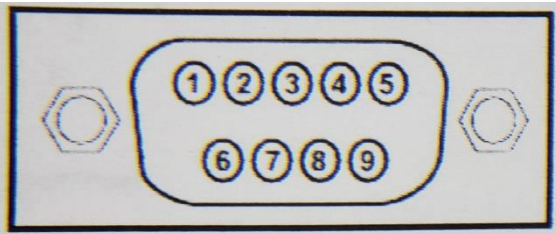
<p><b>Band Data Input Connector</b></p>  <p><b>As Viewed from the Rear of the Unit</b></p>	<p><b>Pin1:</b> Ground</p> <p><b>Pin2:</b> Band Data A (Yaesu, Elecraft, etc.)</p> <p><b>Pin3:</b> Band Data B (Yaesu, Elecraft, etc.)</p> <p><b>Pin4:</b> Band Data C (Yaesu, Elecraft, etc.)</p> <p><b>Pin5:</b> Band Data D (Yaesu, Elecraft, etc.)</p> <p><b>Pin6:</b> Band Data Voltage (Icom)</p> <p><b>Pin7:</b> Transmit Signal</p> <p><b>Pin8:</b> Not Used</p> <p><b>Pin9:</b> Not Used</p>
---	---

The mating female connector, along with a matching backshell, is included as part of the kit. However, the multi-conductor cable as well as the radio end connector have not been included. You will need to acquire them before making the interface cable. The following sections will provide as much guidance as possible regarding the creation of this cable for different radios. If your radio does not match with any of the following figures, please refer to your radio’s operating manual for guidance on obtaining band data and the transmit signal.

## INTERFACING WITH ICOM RADIOS

Most Icom transceivers provide Band Data and the Transmit Signal on a rear panel 13-pin DIN accessory jack. Figure 1 shows the pinouts for the 3 wires needed for the interface.

**Important Note:** Unfortunately, the 13-pin Accessory jack is also used for other functions such as inputs from a sound card and RTTY Keying input. If you are using any of these functions, this jack will already have a connector in place. You will need to evaluate the possibility of splitting out a second 3-wire cable from the connector to obtain the necessary interface lines.

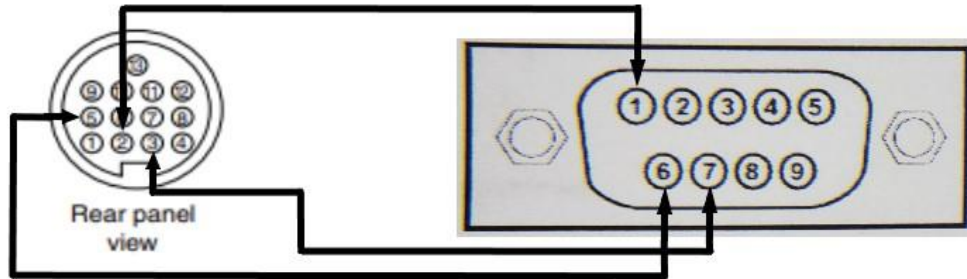

Figure 1 - Typical Icom 13-pin Accessory Jack Interface

The Icom IC-746 and IC-735 (and perhaps others) provide the needed data lines via a separate 7-pin DIN connector labeled ACC-2. Figure 2 shows the details.

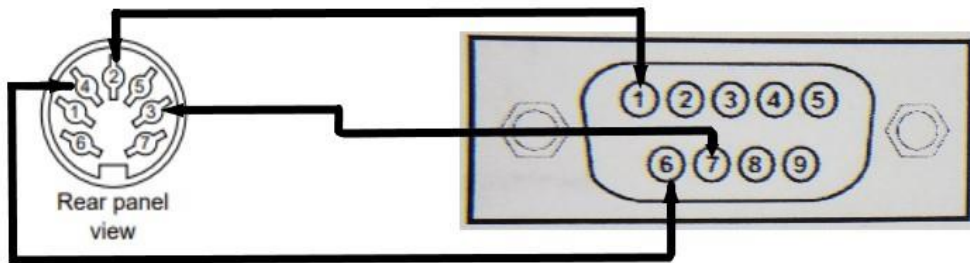

Figure 2 - Icom IC-746 / IC-735 ACC2 Jack Interface

### INTERFACING WITH YAESU RADIOS

Most of the newer Yaesu radios provide both band data and the transmit signal from a 10-pin linear jack on their rear panel. Refer to Figure 3 for the pinout of this interface.

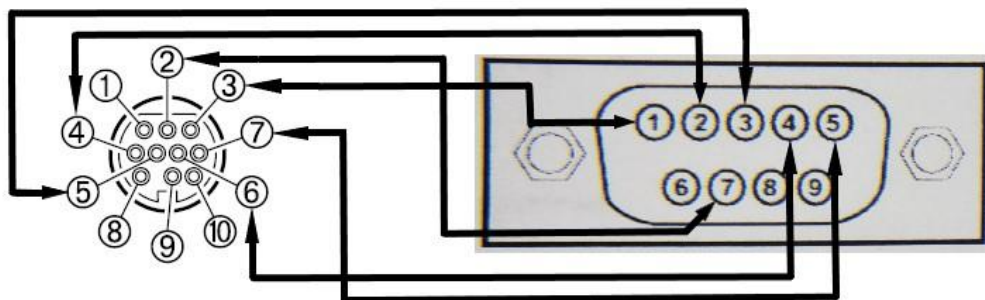

Figure 3 – Typical Yaesu 10 pin Linear Jack Interface – as viewed from the rear panel.

The Yaesu FTdx-101 line of transceivers use a DB-15 connector for their linear port. Refer to Figure 4 for the pin-out of this interface.

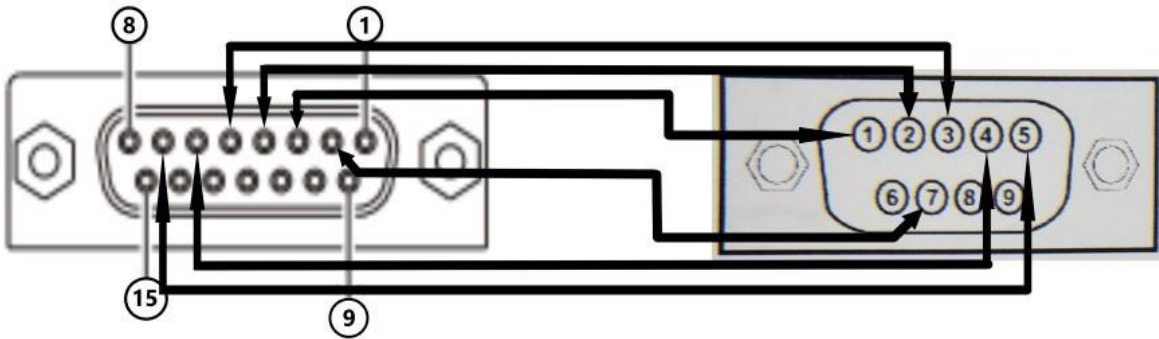

Figure 4 - Yaesu FTdx-101 Linear Jack Interface – as viewed from the rear panel.

The Yaesu FT-991A uses an 8-pin mini-DIN for the linear/tuner multi-function connector on the back of the radio. Refer to Figure 5 for the pinout of this interface.

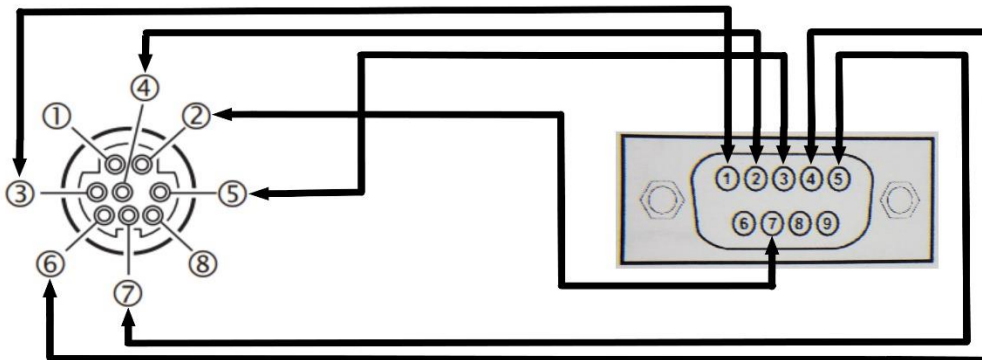

Figure 5 - Yaesu FT-991A Linear/Tuner Jack Interface – as viewed from the rear panel.

Some older Yaesu radios have an 8-pin DIN Band Data jack. Figure 6 illustrates that interface.

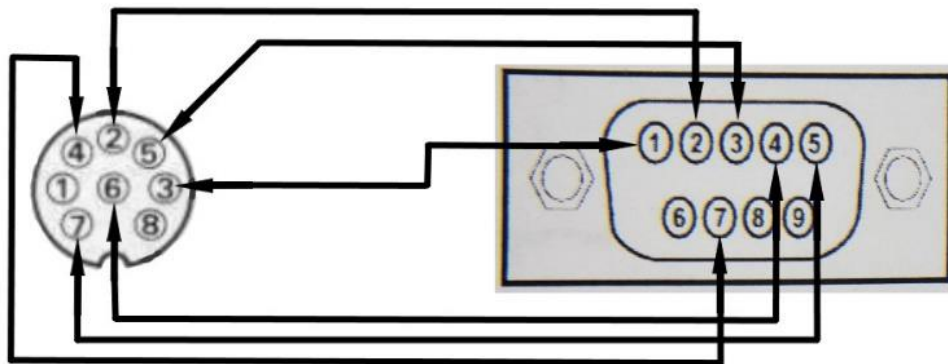

Figure 6 – Typical Yaesu 8-pin DIN Band Data Jack Interface - as viewed from the rear panel.

## INTERFACING WITH ELECFRAFT RADIOS

Elecraft transceivers provide 4-line BCD band data as well as the transmit signal via a rear panel, 15-pin sub-D connector. Figure 7 below shows this interface.

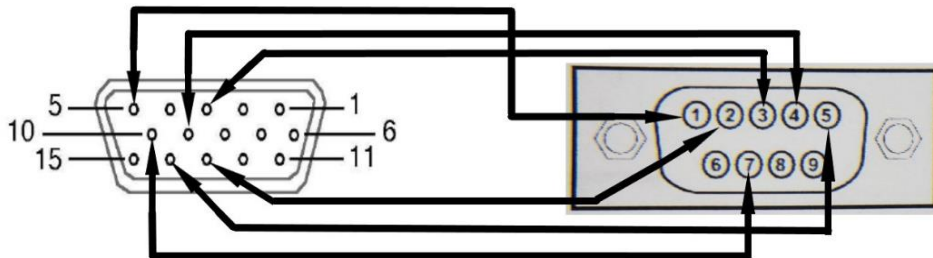

Figure 7 - Elecraft K3 Accessory Jack Interface - as viewed from the rear panel

## INTERFACING WITH FLEX RADIOS

### FLEX 5000 SERIES AND EARLIER

The ability to obtain band data from Flex radios prior to the newer 6000 series is spotty, at best. The Flex 5000 provides a FlexWire™ Peripheral Interface Bus which use I<sup>2</sup>C to interface with external devices. According to the Flex 5000 User Manual, PowerSDR is configured to communicate to the external devices via this interface. Of course, an external interface board that can receive and interpret the FlexWire™ signals is required as well as cabling from this external board to the DB-9 band data input connector on the back RAAS-4a Remote Antenna Switch.

A search of the Internet found the following third-party product from K3TUF:

- <http://www.k3tuf.com/FW.html>

Note: The above referenced product has not been tested by WA4MCMkits and is only offered as an example. The kit builder is responsible for determining its actual usability for obtaining band data.

### FLEX 6000 SERIES

#### BAND DATA

Flex 6000 series radios require an FTDI CH232HM USB cable (Digi-key PN 768-1105-ND) as well as SmartSDR configuration in order to obtain the required 4-bit BCD band data codes. Please refer to the following document from Flex Radio for guidance:

[SmartSDR USB Cable Interface Guide](#)

Follow the instructions for configuring the output for the **BCD** cable type, and the BCD type to **HF\_BCD**. The document's section about the *Array Solutions BandMaster III* provides similar instructions to those needed for the RAAS-4a and RAAS-8a Remote Antenna Switches. Refer to the Table 2 below for details of the cable pin-out:

Table 2 - Flex Radio 6000 Series Cable Pin-out

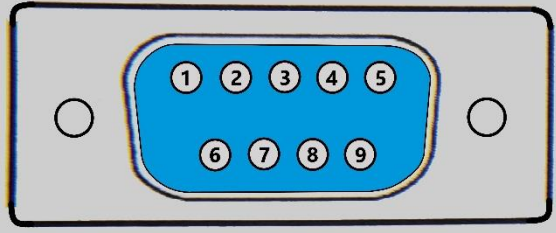
<p><b>DB-9 Female Connector</b></p>  <p><b>As viewed from the solder cup side</b></p>	<p><b>Pin1:</b> CH232HM black wire</p> <p><b>Pin2:</b> CH232HM orange wire</p> <p><b>Pin3:</b> CH232HM yellow wire</p> <p><b>Pin4:</b> CH232HM green wire</p> <p><b>Pin5:</b> CH232HM brown wire</p> <p><b>Pin6:</b> Not Used (Icom band data only)</p> <p><b>Pin7:</b> Transmit Lockout Signal (see next section)</p> <p><b>Pin8:</b> Not Used</p> <p><b>Pin9:</b> Not Used</p>
--	--

TRANSMIT LOCKOUT SIGNAL

The transmit lockout signal can be obtained from the rear panel 15-pin accessory port – pin 11. This pin must first be programmed using the SmartSDR application. Go to the Radio menu and select the Tx Band settings. Place a check box in all boxes that correspond with the bands you are using under the ACC TX heading. See the SmartSDR User’s Guide for further details.

WINDOWS COMPUTER INTERFACE (OPTIONAL)

With the optional USB interface board, the operator may remotely control the front panel push buttons using a Windows PC. The following sections provide the necessary information needed to use the interface.

VIRTUAL SERIAL PORT DRIVER INSTALLATION

The USB interface module is based on the Silicon Labs CP2102N USB to UART Bridge IC. On MS Windows PCs with Internet Access, the drivers should be installed automatically when you plug in the module for the first time. Once this is complete, you can identify the ComPort assigned to the module by reviewing the Windows Device Manager as shown below:

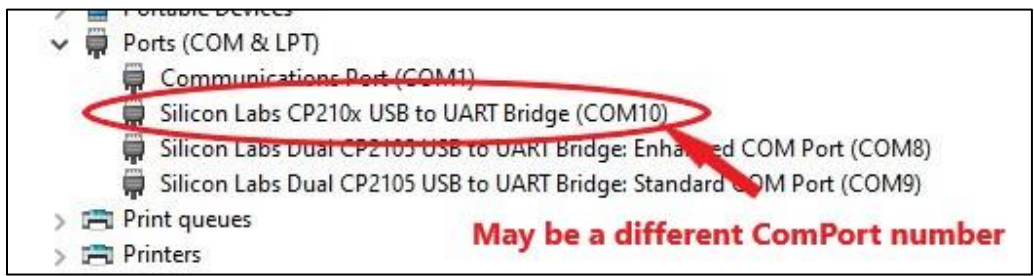

If there are more than one **Silicon Labs CP210x USB to UART Bridge** entry, you can easily identify the one associated with the Switch’s USB module by unplugging it and observing which entry disappears from the Device Manager listing.

If the operating system was not able to automatically load the drivers, or if you are using something other than MS Windows, drivers may be obtained from the Silicon Labs web site at: <https://www.silabs.com/developers/usb-to-uart-bridge-vcp-drivers>.

---

## ANTENNA SWITCH CONFIGURATION

**Important!** In order to use the USB interface, the antenna switch must be in **manual mode**.

The reason for this is that the interface translates the request protocol bytes into virtual “button pushes” inside the antenna switch. If the antenna switch is in Auto Mode, the front panel buttons are disabled for selecting antennas – in this mode, they are only used to program (assign) antennas to the different band data patterns obtained from the transceiver.

---

## PC TO/FROM SWITCH COMMUNICATION PROTOCOL

The USB interface uses a very simple two-way communication protocol.

To change antennas, the sending program should send a two-byte word in the following format:

“A<x>” where <x> is the desired antenna number. For example, if the user wishes to select antenna number 3, send the following 2 bytes:

**A3 (0x41, 0x33)**

Likewise, to determine which antenna is currently selected, send a two-byte query in the following format:

**A? (0x41, 0x3F)**

And read the switch’s response which will be in the same format as the antenna selection word. For instance, if the currently selected antenna is number 2, the following 2 bytes will be returned:

**A2 (0x41, 0x32)**

**Important!** The ability to be able to remotely change the switch’s mode requires the following minimum hardware versions:

- Main controller circuit board version 6.2. or later.
- USB Interface Module version 4.1, or later

To toggle the mode (Auto or Manual), the sending program should send a two-byte word in the following format:

**MT (0x4D, 0x54)**

Similar to querying for the current antenna, to determine the switch’s current mode, send a two-byte query in the following format:

**M? (0x4D, 0x3F)**

And read the switch’s response which will be in one of the following two formats:

**MM (0x4D, 0x4D) for Manual Mode; MA (0x4D, 0x41) for Auto Mode**

## SUPPLIED WINDOWS REMOTE CONTROL APPLICATION

The USB interface module comes with a companion MS Windows application that can be used to remotely control the antenna switch. This application is only supported on the Microsoft Windows operating systems at this time.

The application is a stand-alone executable that can be copied anywhere on your hard drive you desire. It can be found on the flash drive that came with your switch kit: **AntennaSwitchController.exe**.

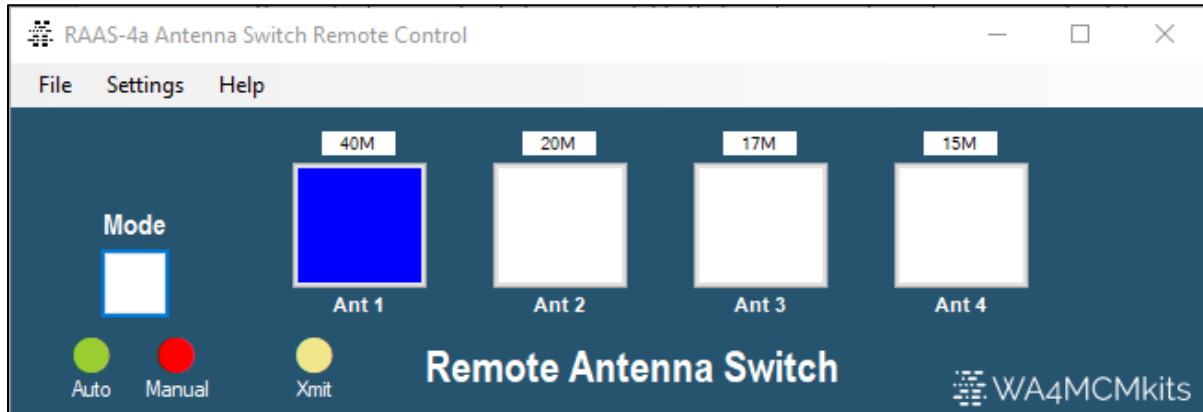

### ***Application Settings:***

**Antenna Button Labels** – Enter descriptive labels for each front panel antenna button. Note that only the first four labels will be used for the RAAS-4a model switch.

**Antenna Switch Model** – Click on the radio button that matches your particular switch’s model. This will automatically change the number of antenna buttons on the front panel.

**ComPort** – Select the ComPort that corresponds to the switch’s USB interface.

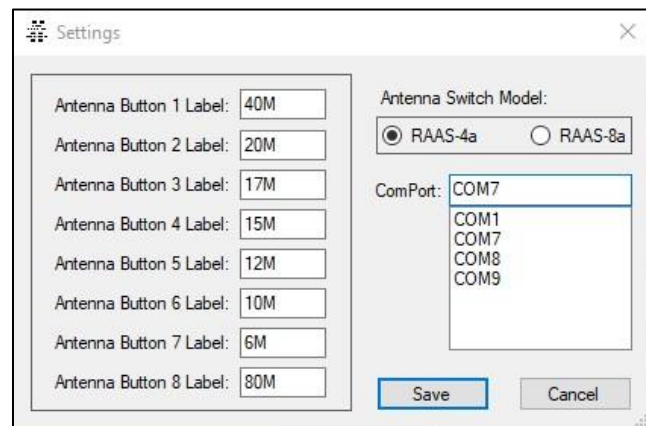

To identify which ComPort belongs to the switch, follow the steps listed below:

- While the switch’s USB interface is plugged in, note the Comports displayed in the **Settings** dialog box.
- Close the **Settings** dialog box and unplug the USB interface cable.
- Reopen the **Settings** dialog box and note which ComPort disappeared – this is the switch’s ComPort.
- Plug the USB interface cable back in and reopen the **Settings** dialog box. Select the switch’s ComPort and Save the settings.
- You may need to restart the application for the change to take effect.



## INTEGRATING WITH REMOTEHAMS SERVER

We worked with the folks at [RemoteHams.com](https://www.remotehams.com/) to add support for both switch models to their **RCForb** server software. Information regarding RemoteHams can be found at the following URL:

<https://www.remotehams.com/>.

The RemoteHams web site has all the information needed to set up and use their software, so this document will not cover that. We will only highlight the steps needed to integrate the RAAS-4/8 switches with the **RCForb** server. Please follow the steps below for details on how to integrate with the RCForb server:

- Install the RCForb server software – These steps assume that the **RCForb** server has already been installed on your PC.
- Open the **Options** menu and select **Other Device Configuration** as shown below. This will display the **Radio Configuration Wizard** with the Other Devices tab selected. The applicable settings are in the center column – **Switch Support (Relay Boards)**.

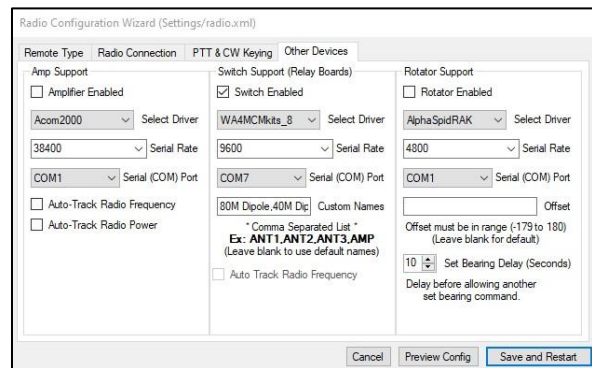
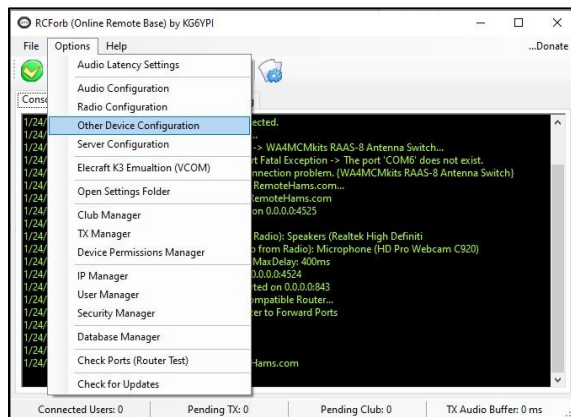

- **Select Driver** – Open the **Select Driver** drop-down box and select the appropriate switch model from the options provided – either WA4MCMkits\_4 (RAAS-4a) or WA4MCMkits\_8 (RAAS-8a).
- **Serial Rate** – Leave the baud rate at 9600
- **Serial (COM) Port** – Open the **Serial (COM) Port** drop-down box and select the ComPort associated with the switch’s USB interface.
- **Custom Names** – If you wish to your remote clients see real-world names describing the antennas connected to the different buttons, enter a comma-delimited string in the Custom Names text box. Enter the number of names that match the number of buttons on your switch model. You may also enter the word **“disabled”** (without the quotes) to designate any open switch positions – this will remove that button from the remote client’s display. If the number of labels entered is less than the number of buttons available, the remaining buttons will contain the default label (SW1, SW2, etc.).
- Click the **Save and Restart** button.

## ANTENNA SWITCH OPERATION

Antenna selection is governed by one of two modes of operation:

- Manual Mode – The operator must manually select the desired antenna by pressing a front panel button.
- Automatic Mode – Changing the operating band on the connected radio will automatically select the antenna that has been assigned to that band.

The operating mode is toggled between Manual and Automatic by pressing and releasing the front panel Mode pushbutton.

## ANTENNA SELECTION SIGNAL DESCRIPTION

This antenna switch selects the desired antenna by sending one of the following signals up the main feedline via a bias-T filter:

- Antenna 1: No signal – antenna #1 is selected by default
- Antenna 2: The positive half of a rectified 12V rms sine wave. This will forward bias diode D2 in the remote relay box which will supply the voltage to both relays K2 and K3. This will direct the RF output through the normally closed contact of relay K1, then on to the normally open contact of relay K2 which is connected to the antenna #2 SO-239 connector.
- Antenna 3: The negative half of a rectified 12V rms sine wave. This will forward bias diode D1 in the remote relay box that will supply the voltage to relay K1. This will direct the RF output through the normally open contact of relay K1, then on to the normally closed contact of relay K3 which is connected to the antenna #3 SO-239 connector.
- Antenna 4: The full 12V rms AC signal. This will forward bias BOTH diodes D1 and D2 in the remote relay box which will cause ALL relays to energize, thus directing the RF output through the normally open contact of relay K1, then on to the normally open contact of relay K3 which is connected to the antenna #4 SO-239 connector.

## MANUAL MODE

The antenna switch is in manual mode when the RED front panel LED is illuminated.

To select the desired antenna, simply push the corresponding antenna pushbutton. The button's LED will illuminate indicating that the antenna has been selected.

## AUTOMATIC MODE

The antenna switch is in Automatic Mode when the GREEN front panel LED is illuminated.

While in this mode, antennas will be automatically selected based on the band currently set by the connected transceiver. For this to work, the operator must first assign a desired antenna for each band supported by the radio.

**Note – Automatic mode is only available if band data information has been obtained from the transceiver via the Band Data Input connector on the back of the controller unit. If the antenna switch doesn't see any band data, it will rapidly flash all 4 antenna buttons.**

The following sections describe how to assign an antenna to a particular band as well as how to unassign an antenna.

### ASSIGNING ANTENNAS

To assign an antenna to a particular band, please follow the step-by-step instructions below:

1. Select the operating band on the connected radio. If the band hasn't already had an antenna assigned, the 4 front panel antenna buttons will be flashing sequentially. If a single antenna button is illuminated, and it is not the desired antenna, you must first skip to the next section to unassign this antenna.
  2. Press and hold the button for the desired antenna until it illuminates.
  3. Repeat steps 1 and 2 for the remaining bands that are supported by the connected radio.
- 

### UNASSIGNING ANTENNAS

To unassign an antenna from a particular band, please follow the step-by-step instructions below:

1. Select the operating band on the connected radio.
2. Press and hold the button associated with the antenna being unassigned until the 4 front panel antenna buttons start flashing sequentially.
3. If you need to unassign an antenna from another band, set the radio to that band and repeat steps 1 and 2.

APPENDICES

TROUBLESHOOTING

Please refer to Table 3

Table 3 - Troubleshooting Matrix

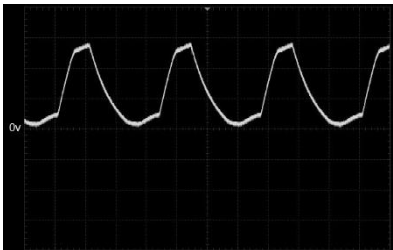
Symptom	Possible Solution
All the antenna LEDs are flashing rapidly.	<p>The antenna switch is in automatic mode and there is no band data information coming from a connected radio.</p> <p>Check the Band Data Input connector to make sure it is tight.</p>
The antenna LEDs are flashing sequentially.	<p>The antenna switch is in automatic mode, but no antenna has been assigned for the currently selected operating band.</p> <p>Assign an antenna by following the steps in the Assigning Antennas section.</p>
The yellow XMIT LED is not illuminated while transmitting.	<p>The antenna switch is not receiving a transmit signal from the connected radio.</p> <p>Ensure pin 7 on the Band Data Input connector is being pulled to ground by the connected radio.</p>
The remote Switch box is not selecting the correct antenna.	<p>There is a problem with the 12 VAC Triac selection signal being sent to the relay box.</p> <p>Check to make sure that the control cable is connected between the controller and the external bias-T box.</p> <p>Remove the controller’s case top and observe the 3 LEDs located on the front left of the circuit board. The LED corresponding to the selected antenna (except antenna #1) should be illuminated. If not, then there is a problem with the microcontroller. Try turning the controller off and on via the front toggle switch. If the LED still doesn’t illuminate, then the microcontroller has failed – contact the seller for a replacement microcontroller.</p> <p>If the LEDs are correct, and you have an oscilloscope, check the signal at the cathode (banded) end of diode D7. The following waveforms are typical for the selected antenna:</p> <div style="display: flex; align-items: center;"> <div style="margin-right: 20px;">Antenna 2:</div>  </div>

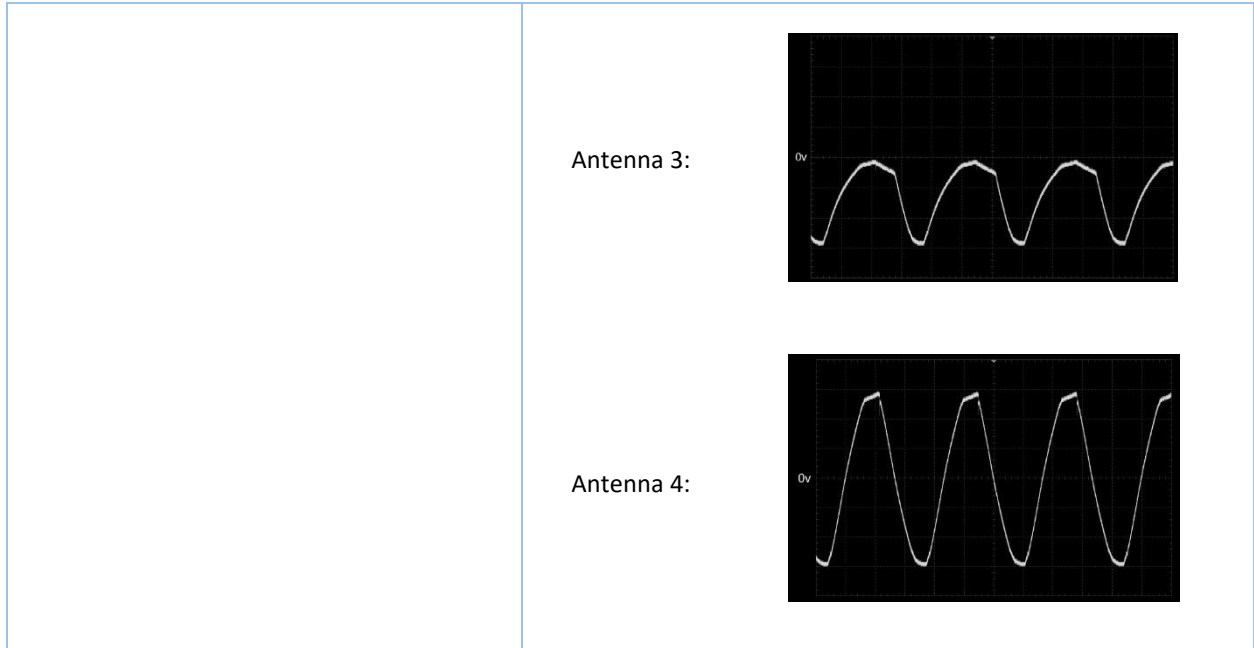

## REMOTE RELAY BOX MOUNTING GUIDANCE

Since everyone's situation is different as far as their antenna farm is concerned, I specifically left any remote relay box mounting hardware out of the kit in order to keep the overall cost down. While Some may need to mount the relay box to the underside of their house's eaves, others may need to mount it at the top of their tower. Still others, like me, have all of their antennas in their attic, and would only need to place the remote relay box on the floor of the attic.

With this in mind, I have compiled a list of possible mounting solutions that I have gathered based on feedback received from customers over the past couple of years. Whichever one fits your situation, please make sure you follow these guidelines:

- When mounting outside exposed to the weather, always mount the remote relay box upside down (RF connectors pointing towards the dirt).
- Always employ "drip loops" in the coaxial cables connected to the remote relay box to prevent water from running down the cable and into the RF connectors and/or the relay box itself.
- If you have to drill holes for mounting brackets, etc., consider doing so in the relay box's cover (the part with the RF connectors) so that these holes will also be facing down. Also, consider tapping the holes with a fine thread so that some sort of sealant such as Loctite may be utilized to prevent water incursion – the fine thread is needed due to the low enclosure wall thickness.
- Consider drilling a small weep hole in the relay box's lid to allow condensation to escape as well as to prevent any water buildup.
- Make sure that the supplied neoprene gasket is not bunched up.

Note: I relish customer feedback and use it to improve both this manual as well as the assembly manual. If you have fabricated your own mounting solution, please consider sending me a description (pictures would be a plus!). I will include it in future revisions (with attribution, of course).

Here are some mounting solutions (in no particular order):

### MOUNTING BRACKETS

If you're mounting the remote relay box on a tower or other structure with cross members, you can source aluminum angle stock from a big-box hardware store and fabricate a mounting bracket. The bracket can then be attached to the relay box in a couple of ways:

- To the lid of the relay box with machine screws (drill the mounting holes carefully so as not to damage the circuit board). The lid is preferred because it will be pointing down, thus minimizing water incursion through the mounting holes.
- To other parts of the relay box using machine screws or weatherproof adhesive. There are many commercially available adhesives on the market that can be picked up at the local hardware or big-box home improvement stores. Using adhesive is preferred due to the fact that you will not need to create any other holes in the enclosure.

How you mount this bracket to the tower would depend on the tower, but appropriately sized U-bolts would be the most common method.

### ZIP TIES

Heavy duty, UV-resistant zip ties may be used to encircle both the remote relay box as well as things such as tower cross members, tree limbs, etc.

---

### STAINLESS STEEL HOSE CLAMPS

Similar to zip ties, stainless steel hose clamps come in sizes large enough to encircle both the remote relay box as well as things such as tower cross members, tree limbs, etc.

---

### WEATHERPROOF ENCLOSURES

There are many weatherproof enclosures on the market from numerous manufacturers. These are mostly used by public utilities, electrical contractors, or others who require a secure, dry environment for various electrical and/or electronic equipment. Many designs have external mounting flanges making it possible to install without breaking any weather seal.

If you choose to go this route, consider purchasing an enclosure that is large enough for expansion in the event you need to install additional equipment such as remote antenna tuners, pre-amps, etc.

Simply use whatever method makes sense to mount the remote relay box inside of the larger enclosure.

---

### UNDER THE EAVES

Mounting the remote relay box under your house's eaves requires drilling holes in the bottom of the enclosure, then using the appropriate screws (depending on the eave's material) to attach it upside down. Once the bottom of the enclosure has been secured, re-attach the box's lid using the machine screws provided with the enclosure.