



PSR-100 Mk2 Portable Satellite Antenna Rotor Kit

Assembly Manual

CONTENTS

Getting Started1

 Required Tools and supplies1

 Recommended Tools1

 Parts Inventory2

 Tips for Successful Soldering9

Electronic Components Assembly11

 PSR-100 Main Circuit Board11

 Wire Harnesses, Switches and Az Motor Preparation17

 PSR-100 WiFi Access Point Assembly20

 Electronic Components Post-Assembly Testing21

Mechanical Components Pre-assembly25

 Main Body Layer One25

 Main Body Layer Two27

 Main Body Layer Three28

 Elevation Motor Mounting Bracket30

Final Assembly35

Calibration and Testing44

 Elevation Potentiometer44

 Azimuth Potentiometer45

 Live Testing48

Troubleshooting50

Circuit Board Images60

 Main Board, MCU Module, and Analog to Digital Converter Module:60

 WiFi Access Point Module Board:61

Schematic Diagrams62

GETTING STARTED

These instructions are specifically structured to guide you through the steps required to easily complete the assembly of the portable satellite antenna rotor. The order of the sections and steps has been chosen to reduce any instances where awkward soldering or physical assembly would be needed. For instance, resistors are installed early in the main board assembly since they sit very close to the circuit board and have less chance of interfering with component placement while installing any later components such as the transistors and voltage regulators.

There are no “hard” soldering tasks on this kit. Anyone with beginner-level or better soldering skills should be able to successfully complete that portion of the assembly.

REQUIRED TOOLS AND SUPPLIES

The following tools and supplies are required to complete the assembly of the remote antenna switch:

- Soldering Iron – At least 60 watts with a thin tip is recommended. A temperature-controlled soldering station would be preferred.
- Heat gun or high temperature hair dryer – for use in shrinking heat shrink tubing.
- Rosin core solder – please see the soldering tips section below for a discussion on choosing between leaded or non-leaded solder compositions.
- Super glue
- Fine point black Sharpie permanent Marker (or similar brand)
- Allen wrenches in the following sizes: 3/32”, 3mm, 2.5mm
- 7/16” Nut Driver
- #1 and #2 phillips-head screwdrivers
- Small needle-nosed pliers
- Small diagonal wire cutters
- Small flush cutter pliers
- Wire strippers



Figure 1 - Required Tools

RECOMMENDED TOOLS







The following tools are recommended to make the assembly process easier and more precise, but are not required:



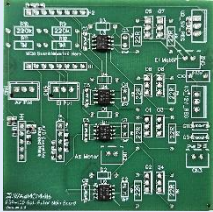

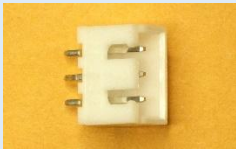



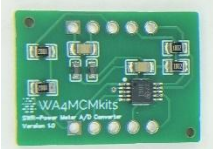

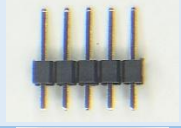
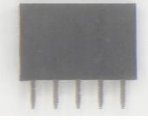
- “Helping Hands” station equipped with a magnifying glass.

PARTS INVENTORY

After unpacking all kit components and hardware, please refer to the following tables to ensure everything has been included and identified before moving to the actual assembly sections of this manual. If anything is missing, please contact the seller for replacements.

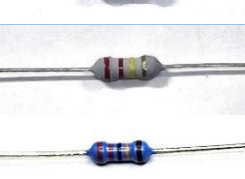
Table 1 –Main Circuit Board Parts

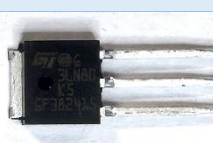
<input checked="" type="checkbox"/>	Component	Qty	Circuit Designator(s)	Identifying Marks	Image
<input type="checkbox"/>	Circuit Board – Meter Main Board	1	N/A	Version 3.3	
<input type="checkbox"/>	2 Conductor JST XH PCB Header	3	CN1, CN2, CN3	N/A	
<input type="checkbox"/>	3 Conductor JST XH PCB Header	2	CN4, CN5	N/A	
<input type="checkbox"/>	10 nf 50V Ceramic Disk Capacitor	4	C1, C2, C3, C4	103	
<input type="checkbox"/>	100 nf 50 V Ceramic Disk Capacitor	6	C5, C6, C7, C8, C9, C11	104	
<input type="checkbox"/>	330 nf Ceramic Disk Capacitor	1	C10	334 (this may vary)	
<input type="checkbox"/>	1N4148 Small Signal Diode	4	D1, D2, D3, D4	1N4148	
<input type="checkbox"/>	Analog-to-digital Converter (ADC) Module	1	N/A	Version 1.0	

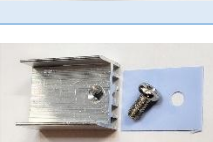
<input checked="" type="checkbox"/>	Component	Qty	Circuit Designator(s)	Identifying Marks	Image
<input type="checkbox"/>	5-pin male pin header	2	H3, H4	N/A	
<input type="checkbox"/>	5-pin female header	2	H3, H4	N/A	
<input type="checkbox"/>	PSR-100 Microcontroller Module	1	N/A	Version 3.1	
<input type="checkbox"/>	8-pin male pin header	2	H1, H2	N/A	
<input type="checkbox"/>	8-pin female header	2	H1, H2	N/A	
<input type="checkbox"/>	22Ω ¼ W Resistor	8	R1, R2, R3, R4, R5, R6, R7, R8	red / red/ black / gold	
<input type="checkbox"/>	4.7kΩ ¼ W Resistor	5	R13, R14, R15, R16, R17	yellow / violet / red / gold	
<input type="checkbox"/>	220kΩ ¼ W Resistor	2	R9, R10	red / red/ yellow / gold -or- Red / red/ black / orange / brown	
<input type="checkbox"/>	1MΩ ¼ W Resistor	2	R11, R12	brown / black / green / gold -or- Brown / black / black / yellow / brown	
<input type="checkbox"/>	N-Channel Power MOSFET	8	Q1, Q2, Q3, Q4, Q5, Q6, Q7, Q8		
<input type="checkbox"/>	LM7805 5V Linear Voltage Regulator	1	U2_5V_REG	LM7805	
<input type="checkbox"/>	TO-220 Heat Sink	1	U2_5V_REG	N/A	









<input checked="" type="checkbox"/>	Component	Qty	Circuit Designator(s)	Identifying Marks	Image
<input type="checkbox"/>	LM7812 12V Linear Voltage Regulator	1	U3_12V_REG	UTC LM7812L	

Table 2 – Main Body Parts



<input checked="" type="checkbox"/>	Component	Qty	Circuit Designator(s)	Identifying Marks	Image
<input type="checkbox"/>	Main Body Layer One	1	N/A	N/A	
<input type="checkbox"/>	Main Body Layer Two	1	N/A	N/A	
<input type="checkbox"/>	Main Body Layer Three	1	N/A	N/A	
<input type="checkbox"/>	Main Body Top Plate	1	N/A	N/A	
<input type="checkbox"/>	Elevation Motor Mounting Bracket	1	N/A	N/A	
<input type="checkbox"/>	Lower Antenna Mounting Arm	1	N/A	N/A	
<input type="checkbox"/>	Upper Antenna Mounting Arm	1	N/A	N/A	

<input checked="" type="checkbox"/>	Component	Qty	Circuit Designator(s)	Identifying Marks	Image
<input type="checkbox"/>	12VDC 2rpm Motor	2	N/A	JGY-370	
<input type="checkbox"/>	10kΩ Linear Taper Potentiometer	2	N/A	B10K Alpha	
<input type="checkbox"/>	DC Power Receptacle – Panel Mount	1	N/A	N/A	
<input type="checkbox"/>	2 conductor cable assembly - 120mm long	3	N/A	N/A	
<input type="checkbox"/>	3 conductor cable assembly - 120mm long	2	N/A	N/A	
<input type="checkbox"/>	1/8" Heat Shrink Tubing – 6 inches long	1	N/A	N/A	
<input type="checkbox"/>	FB-43-2401 Ferrite Bead	1	N/A	N/A	
<input type="checkbox"/>	1/4-20 Brass Threaded Insert	1	N/A	N/A	
<input type="checkbox"/>	12" 24AWG Stranded Hookup wire - Yellow	1	N/A	N/A	
<input type="checkbox"/>	24" 24AWG Stranded Hookup wire - Red	1	N/A	N/A	

<input checked="" type="checkbox"/>	Component	Qty	Circuit Designator(s)	Identifying Marks	Image
<input type="checkbox"/>	24" 24AWG Stranded Hookup wire - Black	1	N/A	N/A	
<input type="checkbox"/>	6mm I.D. x 14mm O.D Ball Bearing	2	N/A	N/A	
<input type="checkbox"/>	6mm to 6mm set-screw shaft coupler	1	N/A	N/A	
<input type="checkbox"/>	30 Tooth, 6mm D-Bore Pinion Gear	2	N/A	This part may vary in color as well as bore shape	
<input type="checkbox"/>	45 Tooth Hub-mount Gear	1	N/A	This part may vary in color	
<input type="checkbox"/>	15 Tooth 1/4" Bore Pinion Gear	1	N/A	N/A	
<input type="checkbox"/>	1/4" Bore Set-screw Hub	1	N/A	N/A	
<input type="checkbox"/>	6mm D-bore Double Sonic Hub	1	N/A	N/A	

<input checked="" type="checkbox"/>	Component	Qty	Circuit Designator(s)	Identifying Marks	Image
<input type="checkbox"/>	6mm D-bore Single Sonic Hub	1	N/A	N/A	
<input type="checkbox"/>	6mm x 60mm D Shaft	2	N/A	N/A	
<input type="checkbox"/>	3" Square Ball Bearing Turntable	1	N/A	N/A	
<input type="checkbox"/>	6-32 x 1/4" pan head machine screw	14	N/A	N/A	
<input type="checkbox"/>	M3 x 6mm Pan Head Screw	8	N/A	N/A	
<input type="checkbox"/>	M4 x 10mm Pan Head Screw	6	N/A	N/A	
<input type="checkbox"/>	M4 x 20mm Pan Head Screw	3	N/A	N/A	
<input type="checkbox"/>	M4 x 30mm Pan Head Screw	2	N/A	N/A	

Table 3 - WiFi Access Point Parts

<input checked="" type="checkbox"/>	Component	Qty	Circuit Designator(s)	Identifying Marks	Image
<input type="checkbox"/>	WiFi Access Point Module	1	N/A	Version 3.1	
<input type="checkbox"/>	WiFi Access Point Enclosure Bottom	1	N/A	N/A	
<input type="checkbox"/>	WiFi Access Point Enclosure Top	1	N/A	N/A	

TIPS FOR SUCCESSFUL SOLDERING

This kit has been designed to ensure relatively easy soldering. Also, the components have been placed on the circuit boards with plenty of spacing. Finally, we have chosen to use all through hole rather than surface mount components to accommodate beginning kit builders.

If this is your first attempt at building an electronics kit, or it has been a while since you've wielded a soldering iron, please refer to the following soldering tips:

1. Wear safety glasses! Consider using a small fan to blow the soldering fumes away from your nose.
2. Use a good soldering iron, or a temperature-controlled soldering station. A soldering station is preferred since it would likely come with a tip cleaning station. See *Figure 2 - Soldering Station Example* for a common example of an inexpensive soldering station. Decent soldering stations will cost about \$20 to \$30.
3. Consider using a "helping hands" station. Some versions of these also include a magnifying glass which will come in handy with some of the smaller components. Refer to *Figure 3 - "Helping Hands" Example* for an example.
4. Use the thinnest solder appropriate for the project – a diameter of around .032 works well for the type of circuit board soldering encountered on this kit.
5. 63/37 (Tin/Lead) solder is recommended for beginners since the lead content lowers the melting point of the solder which allows for much easier soldering. However, lead can be harmful to humans, so there are non-lead solders available. These non-lead types of solder have their drawbacks – the most prevalent being the high melting temperature. In the end, it is up to the individual to decide which type of solder to use.
6. Allow the soldering iron to reach its working temperature before trying to solder any components. A good working temperature for the types of components used in this kit is between 325° C and 375° C. This will also depend on the type of solder being used – please refer to the solder manufacturer's recommendations for the optimum temperature.
7. Tin the soldering iron by applying a small amount of solder directly on the iron's tip prior to touching the iron to the circuit board and component being soldered. The reason for this is that a tinned tip will transfer heat much faster, thus reducing the amount of time needed to get the solder to flow around the component lead and circuit board pad.
8. Try to structure your soldering activities by placing several components on the circuit board before picking up the soldering iron. This allows for more efficient soldering since the iron will remain tinned throughout this soldering cycle.



Figure 2 - Soldering Station Example



Figure 3 - "Helping Hands" Example

9. Apply the tip of the soldering iron evenly to both the circuit board pad and the component lead first. Then touch the solder to the lead and allow it to spread, or “flow” as it’s known in the trade. When you see the solder flow, you will know that you have a strong, well soldered joint.
10. Don't use too much solder– “the bigger the blob, the better the job” is not true here. Some have described the perfect solder joint as looking like a small Hershey’s Kiss (or a small volcano if you don’t like chocolate).
11. Clean the tip often using brass wool, or a damp sponge. Brass wool has become the preferred material since it will not lower the temperature of the soldering tip. The constant cooling and reheating of the tip can shorten its life due to contraction and expansion. However, a damp sponge will clean the tip as well.
12. Don't move the joint while it is cooling, and don't blow on it to cool it off. This can cause a “cold” solder joint which can result in a high electrical resistance between the component and the circuit board.

For further information, please check out this informative video published on the WA4MCMkits YouTube channel: <https://youtu.be/PRYvPBZxy5o>.

ELECTRONIC COMPONENTS ASSEMBLY

The order in which components are placed on the circuit board does have a bearing on how easy it is to complete the board. The steps listed in this section have been arranged to make it as easy as possible to place and solder the component leads.

PSR-100 MAIN CIRCUIT BOARD

Note: Most of the components on this board all have wire leads. The following tips will help with the placement and soldering of these components:

- The following illustration shows how to “lock” the component in place by slightly bending the leads.

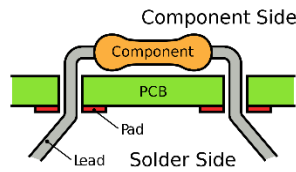

- For the resistors and diodes, use your needle nosed pliers to bend the leads on either side of the component so that they fit the holes provided for that component.
- Trim the leads using your diagonal wire cutters so they only protrude about ½ inch beyond the bottom of the circuit board.
- All components will have their component number printed as close as possible to their outline.
- Where possible, the component’s value will be printed within their outline. If there is no room within the outline, then the value will be printed as close to it as possible.

- 1 Insert each of the 8 **22 Ω ¼ watt resistors (red / red / black / gold)** at their respective locations: **R1, R2, R3, R4, R5, R6, R7 and R8**. Then solder all 16 leads. Once all leads have been soldered, cut the excess leads flush with the solder joint using your diagonal cutters.
- 2 Insert each of the 2 **220k Ω ¼ watt resistors (red / red / yellow / gold)** at their respective locations: **R9 and R10**. Then solder all 4 leads. Once all leads have been soldered, cut the excess leads flush with the solder joint using your diagonal cutters.
- 3 Insert each of the 2 **1M Ω ¼ watt resistors (brown / black / green / brown)** at their respective locations: **R11 and R12**. Then solder all 4 leads. Once all leads have been soldered, cut the excess leads flush with the solder joint using your diagonal cutters.

- 4 Insert each of the 4 **1N4148 Small Signal diodes** at their locations: **D1, D2, D3 and D4**.

Important! - Ensure that the black stripe on each diode aligns with the stripe printed on the circuit board outline as shown in the image below.

Then solder all 8 leads. Once they have been soldered, cut the excess leads flush with the solder joint using your diagonal cutters.

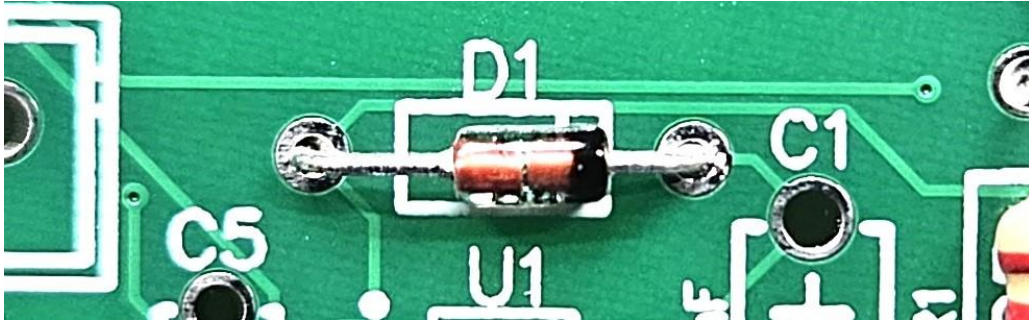

- 5 Insert one of the **2-conductor JST XH PCB Headers** in the location marked **CN1** for the **Az Motor**. Orient the header as shown in the image to the right. Solder both pins. No need to cut off the excess as these pins will not protrude far beyond the bottom of the circuit board.



- 6 Insert the second **2-conductor JST XH PCB Headers** in the location marked **CN2** for the **EI Motor**. Orient the header as shown in the image to the right. Solder both pins. No need to cut off the excess as these pins will not protrude far beyond the bottom of the circuit board.



- 7 Insert the third **2-conductor JST XH PCB Headers** in the location marked **CN3** for the **Pwr**. Orient the header as shown in the image to the right. Solder both pins. No need to cut off the excess as these pins will not protrude far beyond the bottom of the circuit board.



- 8 Insert one of the **3-conductor JST XH PCB Headers** in the location marked **CN4** for the **Az Pot**. Orient the header as shown in the image to the right. Solder all three pins. No need to cut off the excess as these pins will not protrude far beyond the bottom of the circuit board.

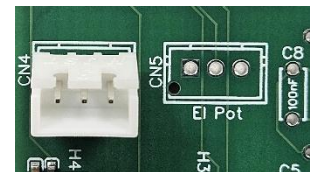

- 9 Repeat step 8 for the remaining **3-conductor JST XH PCB Headers** in the location marked **CN5** for the **EI Pot**. Orient the header as shown in the image in step 8. Solder all 3 pins. No need to cut off the excess as these pins will not protrude far beyond the bottom of the circuit board.

- 10 Insert one of the 8 pin female headers at the location marked: **H1**.
- Turn the circuit board over while holding the header in place and carefully lay the board down on the work surface. Ensure that the 8 pins are still protruding through the circuit board. The weight of the board should ensure that the connector will remain in place while you solder the pins.

Solder **one of the pins** while ensuring that the connector remains flush AND perpendicular with the circuit board. Then solder the remaining 7 pins before moving to the next step.

Important Tip: It is much easier to adjust the positioning of the 8-pin header while only one of the pins has been soldered. Make sure that the header is perpendicular to the circuit board as well as aligned with the header's white outline on the surface of the circuit board before soldering the remaining 9 pins. If need be, reheat the solder connection while manipulating the header in position with your other hand.

- 11 Repeat step 10 for the other 8 pin female header at the location marked: **H2**.



- 12 Insert one of the 5 pin female headers at the location marked: **H3**.
- Turn the circuit board over while holding the header in place and carefully lay the board down on the work surface. Ensure that the 5 pins are still protruding through the circuit board. The weight of the board should ensure that the connector will remain in place while you solder the pins.

Solder **one of the pins** while ensuring that the connector remains flush AND perpendicular with the circuit board. Then solder the remaining 4 pins before moving to the next step.

Important Tip: It is much easier to adjust the positioning of the 5-pin header while only one of the pins has been soldered. Make sure that the header is perpendicular to the circuit board as well as aligned with the header's white outline on the surface of the circuit board before soldering the remaining 4 pins. If need be, reheat the solder connection while manipulating the header in position with your other hand.

- 13 Repeat step 12 for the 5-pin female header at the location marked: **H4**.



- 14 Insert each of the 4 **10 nf ceramic disk capacitors (103)** at their respective locations: **C1, C2, C3 and C4**. Then solder all 8 leads. Once all leads have been soldered, cut the excess leads flush with the solder joint using your diagonal cutters.



- 15 Insert each of the 6 **100 nf ceramic disk capacitors (104)** at their respective locations: **C5, C6, C7, C8, C9 and C11**. Then solder all 12 leads. Once all leads have been soldered, cut the excess leads flush with the solder joint using your diagonal cutters.



- 16 Insert the **330 nf ceramic disk capacitor (334)** at its location **C10**. Solder both leads. Once they have been soldered, cut the excess leads flush with the solder joint using your diagonal cutters.



- 17 Insert the 8 **N-Channel Power MOSFETs** into their respective locations at **Q1, Q2, Q3, Q4, Q5, Q6, Q7 and Q8**. Ensure that their tabs are aligned with the double lines on the circuit board as shown in the image to the right. Slightly spread the outer two leads of each MOSFET to prevent them from falling out of their locations when turning the board over. Solder all of the leads. Once all of the pins have been soldered, trim the excess leads flush with the solder joint using your diagonal cutters.

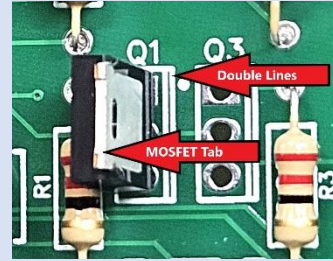

- 18 Prepare the **LM7805 5V Linear Voltage Regulator** by installing the **TO-220 Heat Sink** using the screw provided with the heat sink. Refer to the image below for guidance:

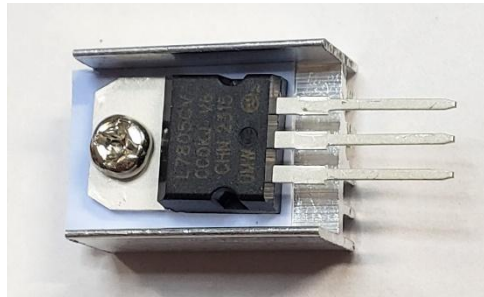

- 19 Insert the **LM7805 5V Linear Voltage Regulator** in its location: **U2_5V_REG**. The bottom of the **TO-220 heat sink** should sit directly on the circuit board.

Important! - Ensure that the "Tab" side of the voltage regulator case aligns with its outline on the circuit board as shown in the image to the right.

Then solder all 3 leads. Once all leads have been soldered, cut the excess leads flush with the solder joint using your diagonal cutters.

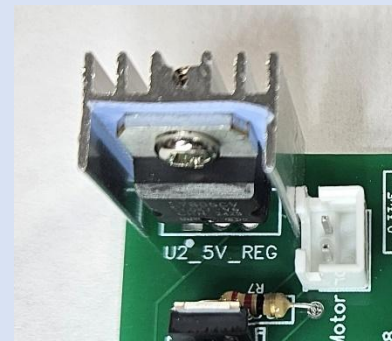

- 20 Insert the **LM7812 12V Linear Voltage Regulator** in its location: **U3_12V_REG**. The size of the circuit board holes will prevent the regulator from sitting flush with the board – this is normal.

Important! - Ensure that the "Tab" side of the voltage regulator case aligns with its outline on the circuit board as shown in the image to the right.

Then solder all 3 leads. Once all leads have been soldered, cut the excess leads flush with the solder joint using your diagonal cutters.

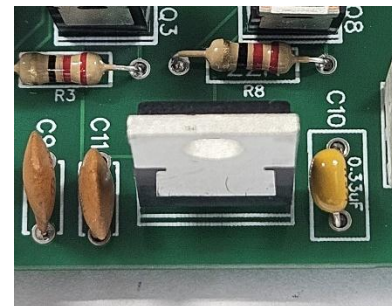

- 21 Insert the short pins of the 2 **5-pin male pin headers** into the underside of the **Analog-to-digital converter (ADC)** module as shown in the image to the right.

Turn the module over while holding the headers in place and carefully lay it down on the work surface. Ensure that the 10 pins are still protruding through the circuit board. The weight of the board should ensure that the connector will remain in place while you solder the pins.

Solder **one of the pins** on each header while ensuring that the connector remains flush AND perpendicular with the circuit board. Then solder the remaining 8 pins before moving to the next step.



Important Tip: It is much easier to adjust the positioning of each 5-pin header while only one of its pins has been soldered. Make sure each header is perpendicular to the circuit board as well as aligned with the header's white outline on the underside of the module before soldering the remaining 4 pins. If need be, reheat the solder connection while manipulating the header in position with your other hand.

- 22 Insert the short pins of the 2 **8-pin male pin headers** into the underside of the **PSR-100 Microcontroller Module** as shown in the image to the right.

Turn the module over while holding the headers in place and carefully lay it down on the work surface. Ensure that the 16 pins are still protruding through the circuit board. The weight of the board should ensure that the connector will remain in place while you solder the pins.

Solder **one of the pins** on each header while ensuring that the connector remains flush AND perpendicular with the circuit board. Then solder the remaining 14 pins before moving to the next step.



Important Tip: It is much easier to adjust the positioning of each 8-pin header while only one of its pins has been soldered. Make sure each header is perpendicular to the circuit board as well as aligned with the header's white outline on the underside of the module before soldering the remaining 4 pins. If need be, reheat the solder connection while manipulating the header in position with your other hand.

- 23 Locate the pin labeled **Pin 1** on the **Analog-to-digital converter (ADC) Module**. Orient this pin so that it corresponds to the Pin 1 label on the left end of header H3 on the main board. Gently insert the module all the way into the two headers (H3 and H4). Please refer to the image below for the proper alignment:

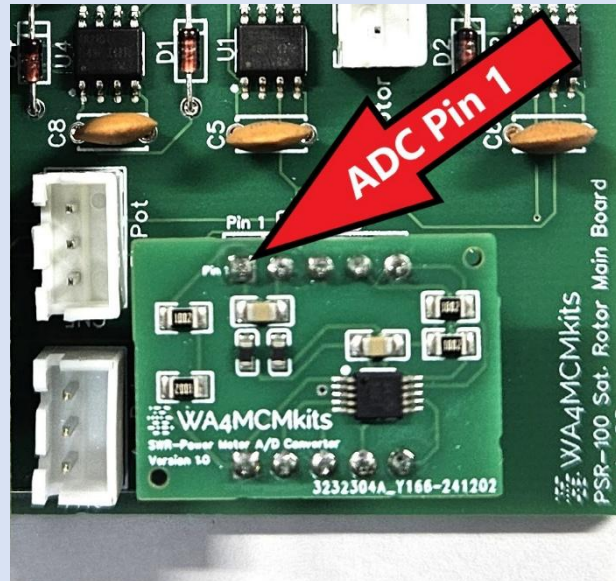

- 24 Align the pins of the two headers on the underside of the **PSR-100 Microcontroller Module** with the mating headers H1 and H2 on the main board, and then gently press the module into the main board's headers. Please refer to the image below for the proper alignment:

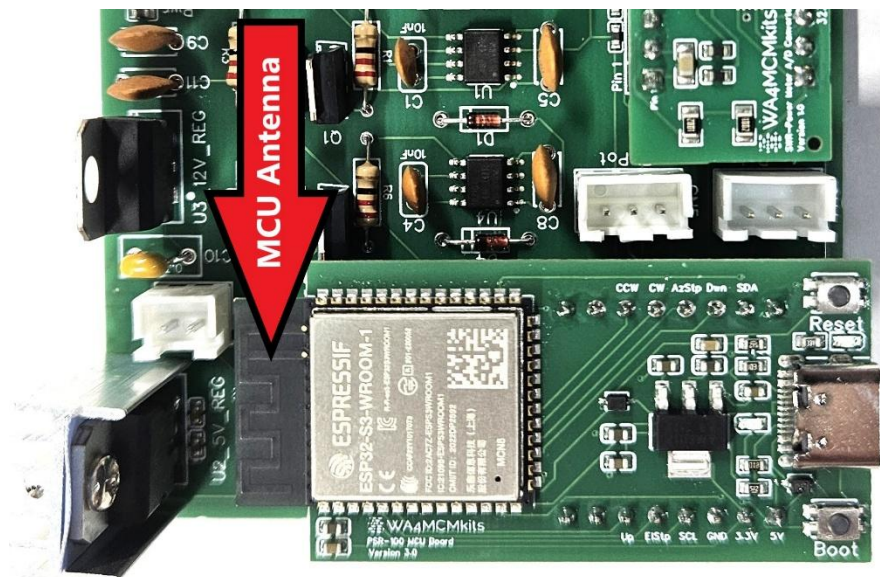

- 25 This completes the assembly of the PSR -100 Main Circuit Board. Set it aside for later when it is tested in the **Electronic Components Post-Assembly Testing** section. Please proceed to the next section:

Wire Harnesses, Switches and Az Motor Preparation.

WIRE HARNESES, SWITCHES AND AZ MOTOR PREPARATION

This section will step you through the preparation of the various wire harnesses used to connect the motors and angle reading potentiometers to the main circuit board. The harnesses destined for the elevation components will need to be extended by soldering 12" lengths of stranded wire to the existing 2- and 3-conductor 120mm cable assemblies.

Please refer to the following guidance for joining the stranded wire to the wires of the existing cable assemblies:

Use wire strippers to remove approximately $\frac{1}{4}$ " of insulation from the ends of both wires. Twist the two wires together as shown in the image below, and the solder them:

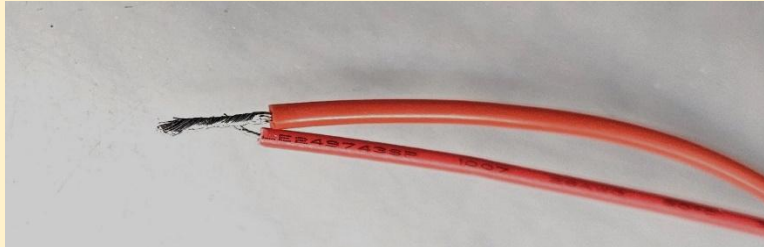

Next, bend the wires as shown in the image below and slip a $\frac{3}{4}$ " piece of $\frac{1}{8}$ " heat shrink tubing over the wires as shown.



Finally, slide the heat shrink tubing over the solder joint so that equal parts extend on either side of the joint and use a heat gun (or other heat source such as a hair drier) to shrink the tubing as shown below:



- 26 Locate one of the **2-conductor 120mm long cable assemblies** as well as the **$\frac{1}{8}$ " Heat Shrink Tubing** and the **Red and Black 24AWG Stranded Hookup wires**.

Cut (2) $\frac{3}{4}$ " long pieces of the **$\frac{1}{8}$ " Heat Shrink Tubing**.

Cut each of the **Red and Black 24AWG Stranded Hookup wires** in half (12" pieces) and set aside one piece of each color to be used in the following step.

Using the method described at the beginning of this section, extend the length of the red and black wires of the **2-conductor 120mm long cable assembly** using the appropriately colored **24AWG Stranded Hookup wires**. The final result should look like the image to the right:



Set the completed cable assembly aside – it will be used to connect the elevation motor to the main circuit board in the **Final Assembly** section.

- 27 Locate one of the **3-conductor 120mm long cable assemblies** as well as the **Yellow 24AWG Stranded Hookup wire**. You will also need the remaining two pieces of the **Red and Black 24AWG Stranded Hookup Wires** left over from the previous step.

Cut (3) $\frac{3}{4}$ " long pieces of the **$\frac{1}{8}$ " Heat Shrink Tubing**.

Using the method described at the beginning of this section, extend the length of all three wires of the **3-conductor 120mm long cable assembly** using the appropriately colored **24AWG Stranded Hookup wires**. The final result should look like the image to the right:

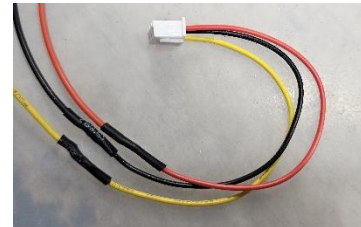

Set the completed cable assembly aside – it will be used to connect the elevation angle reading potentiometer to the main circuit board in the **Final Assembly** section.

- 28 Locate another one of the **2-conductor 120mm long cable assemblies** as well as the **FB-43-2401 Ferrite Bead**.

Wrap two turns of the cable assembly's red wire through the ferrite bead as shown in the image below. Make it so that the ferrite bead is approximately $\frac{1}{2}$ inch from the plug-end of the cable assembly.

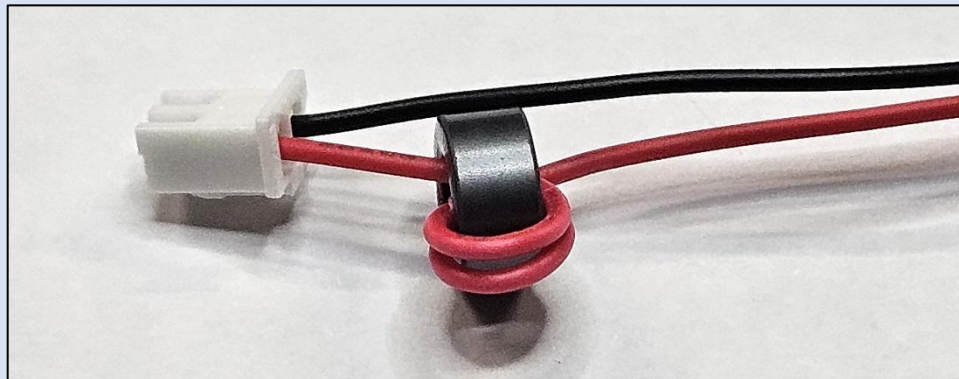

Once the wire has been wound, trim the black wire so that it is the same length as the red wire.

29 Locate the **Panel Mount DC Power Receptacle**.

- Using the **2-conductor cable with ferrite bead assembly** created in the previous step, strip approximately $\frac{1}{4}$ " of insulation from the end of the black lead. Tin the end of the black lead using your soldering iron.

Solder the red lead to the center tab of the power receptacle as shown in the image to the right. Likewise, insert the black lead through both of the ground tabs and solder both as shown in the image.

Set the completed Power Receptacle assembly aside.

It will first be used in the **Electronic Components Post-Assembly Testing** section.

Then it will be mounted on Layer One of the Main Body and connected to the main circuit board in the **Main Body Layer One** section.

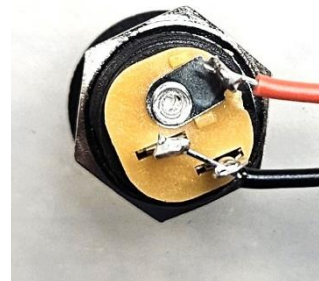

- 30 Locate another one of the **3-conductor 120mm long cable assemblies** as well as one of the **10kΩ Linear Taper Potentiometers**. This potentiometer will be used to transmit the azimuth angles to the PSR-100 Microcontroller Module.

Strip approximately $\frac{1}{8}$ " of insulation from all three leads of the cable assembly. Tin the ends of all leads using your soldering iron.

Orient the potentiometer as shown in the image to the right. Solder the red lead to the top-most tab of the potentiometer as shown in the image to the right. Likewise, solder the black lead to the center tab, and the yellow lead to the bottom-most tab.

Important! The colored wires must be connected as shown in the image, or the azimuth readings being sent to the microcontroller will be reversed.

Set the completed Azimuth Potentiometer assembly aside.

It will first be used in the **Electronic Components Post-Assembly Testing** section.

Then it will be mounted on Layer Three of the Main Body and connected to the main circuit board in the **Main Body Layer Three** section.

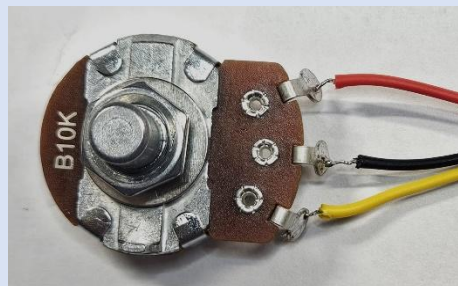

- 31 Cut (2) ¼" long pieces of the ⅛" **Heat Shrink Tubing**.
- Slide one piece over the end of the red wire on the remaining **2-conductor 120mm long cable assembly**. Use your needle nose pliers to bend the stripped end of the wire and crimp it to the positive solder lug on one of the **12VDC 2rpm Motors**.

Repeat the above for the black wire. Refer to the image below for guidance:

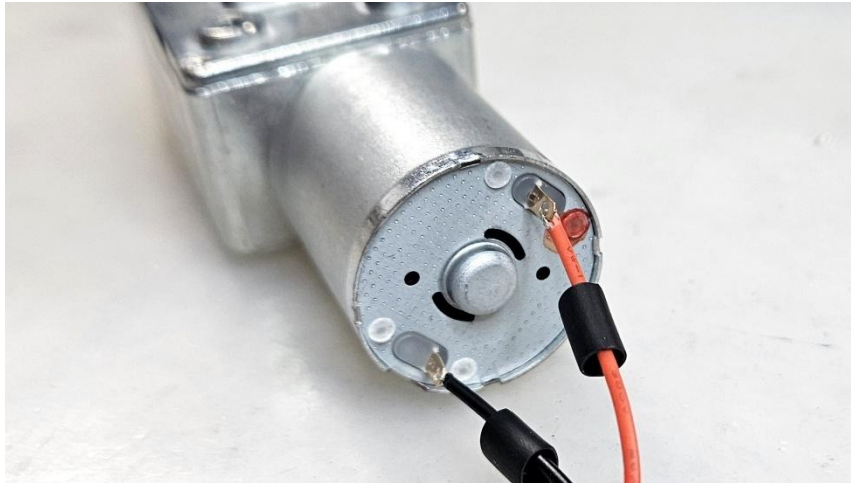

Solder both wires to the solder lugs.

Push the heat shrink tubing flush against the bottom of the motor and use a heat gun to shrink the tubing.

This is the azimuth motor. It will be installed in the **Main Body Layer Two** later on in the assembly process.

- 32 This completes the preparation of all wiring harnesses and switch assemblies. Please proceed to the next section: **PSR-100 WiFi Access Point Assembly**.
-

PSR-100 WIFI ACCESS POINT ASSEMBLY

This section will step through the assembly of the PSR-100's Wifi Access Point "Dongle". The access point consists of a fully assembled ESP32-S3 microcontroller module with a USB-A port designed to be installed in a laptop or PC.

- 33 Insert the **WiFi Access Point Module** into the bottom half of the **WiFi Access Point Enclosure** as shown in the image below:

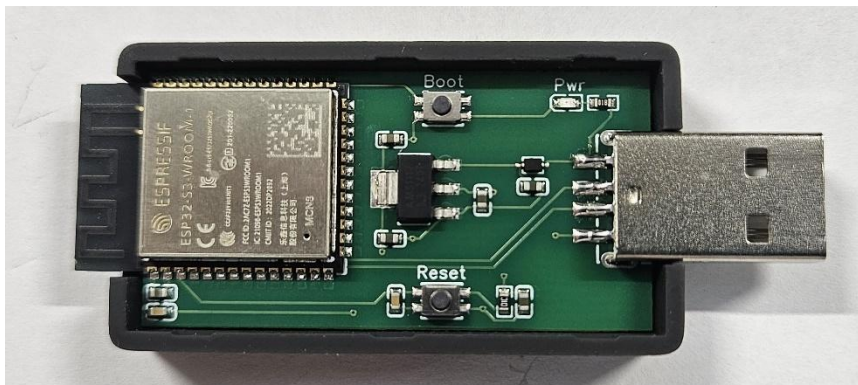

The Access Point Module will only fit into the case bottom one way, so there should be no issues.

- 34 Align the top half of the **WiFi Access Point Enclosure** such that the end tabs match the cutouts in the bottom half and snap the two halves together. This should require a minimal amount of pressure, and you should hear and feel a “snap”. The fully assembled Access Point should look like the image below:



- 35 This completes the assembly of the PSR-100 WiFi Access Point. Please proceed with the next section: **Electronic Components Post-Assembly Testing**.



ELECTRONIC COMPONENTS POST-ASSEMBLY TESTING

This section will test the electronic components assembled in the previous sections. It is best to do this before they are placed inside the rotor’s enclosures, making them fairly inaccessible. It is also much easier to manipulate the components in order to simplify the tests needed.

These tests require that the PSR-100 Mk2 is joined to a WiFi network so that the rotor’s management web site can be used to verify the proper operation of all electronic systems. You will need access to the **PSR-100 Mk2 Operation Manual** for the procedure needed to perform the initial WiFi setup.

Finally, the successful completion of the tests in this section is essential to the future success of the PSR-100 assembly. If any of the tests fail, the underlying cause must be troubleshoot and corrected before continuing with the follow-on sections of the assembly manual.

- 36 Using the components onto which you soldered the wiring harnesses in the **Wire Harnesses, Switches and Az Motor Preparation** section, plug them into their respective sockets on the completed main circuit board:
- **Panel Mount DC Power Receptacle** into the **Pwr** header (**CN3**)
 - **10kΩ Linear Taper Potentiometer** into the **EI Pot** header (**CN5**)
 - **12VDC 2rpm Motor** into the **EI Motor** header (**CN2**)

- 37 Follow the steps outlined in the *PSR-100 Mk2 Operation Manual's Initial WiFi Setup* chapter.
- Once completed, you should be able to use a web browser on a device connected to the same WiFi network as the rotor to access the rotor's management web page. The Home page will look like the image below:

If you don't see the Azimuth and Elevation display windows, there is a problem with the Analog to Digital converter or related circuits. Please refer to the **Troubleshooting** section of this manual.

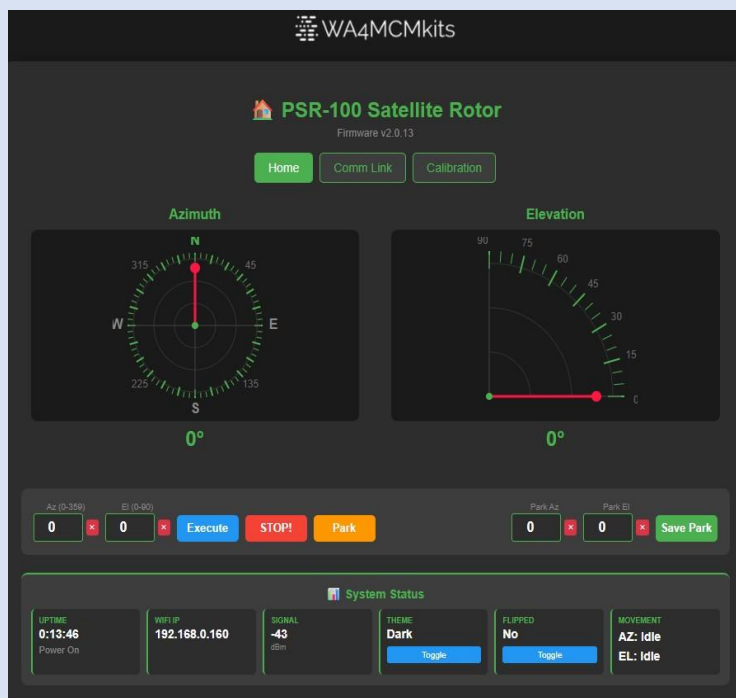

38 Click the Calibration button to move to the calibration page shown below:

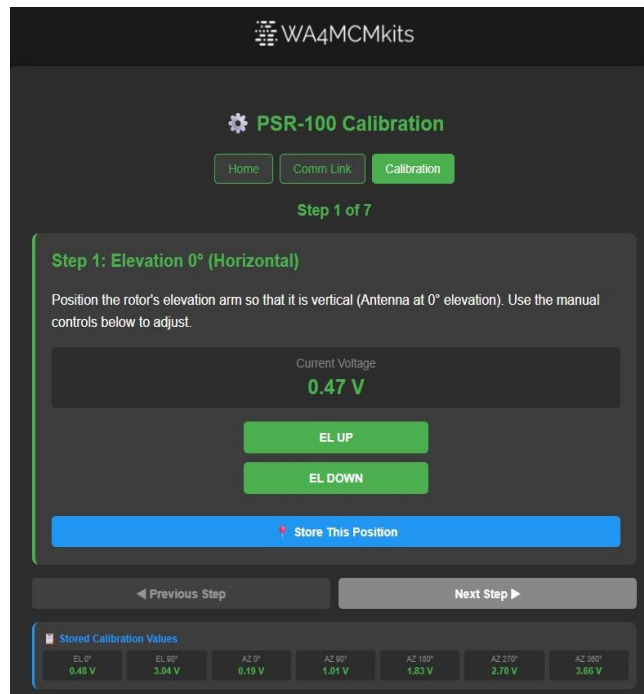

39 Rotate the **10kΩ Linear Taper Potentiometer** and ensure the **Current Voltage** displayed in the center of the Step 1 pane changes with the rotation.



40 Set the **Current Voltage** to about 1.00 and use **EL UP** and **EL DOWN** buttons to make the motor move.



Important Note: For the first few seconds after clicking the buttons, the motor will move very slowly. This is normal as the firmware starts each manual movement by sending widely spaced pulses to the motor to allow for very small angle movements.

41 Relocate the Motor and potentiometer as detailed below:



- **10kΩ Linear Taper Potentiometer** into the **Az Pot** header (**CN4**)
- **12VDC 2rpm Motor** into the **Az Motor** header (**CN1**)

- 42 Click the **Next Step** button **TWICE** so that Step 3 is now active (**Azimuth 0° (North)**). The window will now appear as shown below:

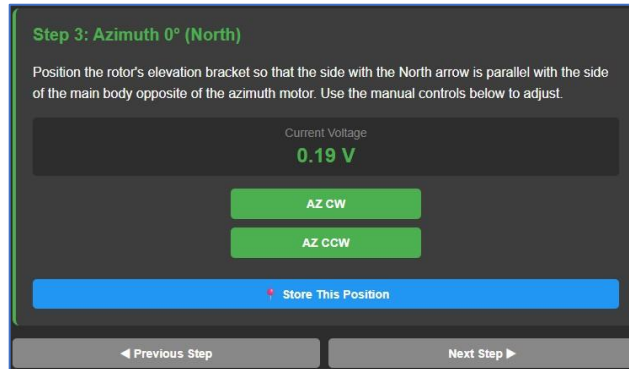

- 43 Rotate the **10kΩ Linear Taper Potentiometer** and ensure the Current Voltage displayed in the center of the Step 3 pane changes with the rotation.

- 44 Set the **Current Voltage** to about 1.00 and use **AZ CW** and **AZ CCW** buttons to make the motor move.

- Important Note: For the first few seconds after moving the toggle, the motor will exhibit some "jerky" movement. This is normal as the firmware starts each manual movement by sending widely spaced pulses to the motor to allow for very small angle movements.**

- 45 Remove the power, then remove all connectors from their respective headers and set the components aside to await their permanent installation during later assembly steps.

- 46 This completes the **Electronic Components Post-Assembly Testing**. Please proceed to the next section: **Mechanical Components Pre-assembly**.

MECHANICAL COMPONENTS PRE-ASSEMBLY

This section covers the assembly of all mechanical components as well as their placement into the respective main body enclosures. The main circuit board will also be installed.

MAIN BODY LAYER ONE

Layer one of the main body houses the main circuit board as well as the power receptacle and manual movement switches. Please refer to the following steps:

- 47 Use a fine point black Sharpie (or similar brand) permanent marker to “paint” the raised lettering on the outer front wall of the **Main Body Layer One**. Be very careful to only color the tops of the raised lettering.

- 48 Refer to the image on the right to understand the orientation of the **1/4-20 Brass Threaded Insert** with respect to its mounting hole in the base of layer one of the main body:

Spread a small amount of super glue around the outer circumference of the brass threaded insert and gently push it into the hole in the center of the base of **Main Body Layer One**. Use the handle of a screwdriver (or another appropriate tool) to push the insert down flush with the top of its mounting hole. You may need to strike the tool used in order to properly seat the brass threaded insert.



Please refer to the following image to view a properly installed brass threaded insert:

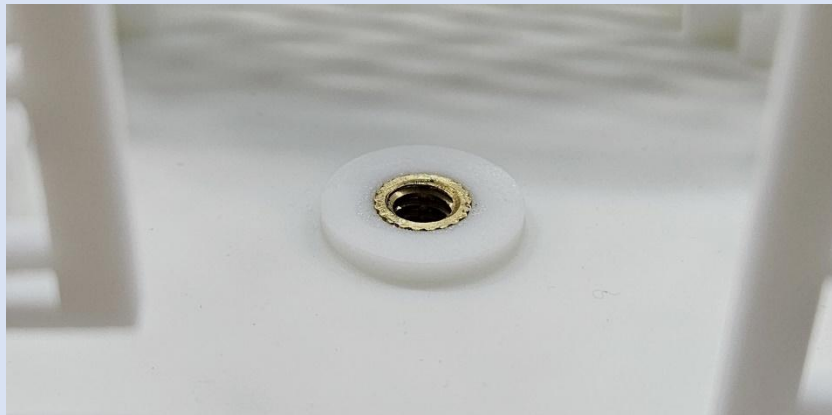

Please note that the threaded insert is installed from the INSIDE of the Main Body Layer One.

- 49 Orient the main circuit board assembly in the bottom **Main Body Layer One** such that the (4) **3-conductor JST XH PCB Headers** are closest to the square opening as shown in the image below:



50



Insert a 6-32 x $\frac{1}{4}$ " pan head machine screw into the left edge mounting block on the bottom of the main body layer one. Slide the left edge of the main circuit board under the screw's head and ensure the board's corners are fitted into the left side corner supports as shown in the image on the left.

Insert a second 6-32 x $\frac{1}{4}$ " pan head machine screw into the right edge mounting block such that the edge of the screw's head securely holds the circuit board in place.

Tighten the left edge screw.



- 51 Remove the control nut from the back of the **Panel Mount DC Power Receptacle** and insert the **2-conductor 120mm long cable assembly** and receptacle through the **12-15 Vdc** hole on the front wall of the **Main Body Layer One**.

Slide the control nut over the cable assembly and carefully screw it onto the control's threads until snug. Be very careful not to cross-thread the control nut. Use a small pair of pliers to gently tighten the control nut.

Caution! Take care when sliding the control nut past the red wire's ferrite bead so as not to damage the control nut's threads. It's a snug fit but can easily be accomplished by orienting the ferrite bead so that the red wire turns are not in the way of the control nut.

Plug the connector end of the cable assembly into the **Pwr** header (**CN3**)

- 52 Refer to the following images for guidance on the proper placement of all **Main Body Layer One** components:



- 53 This completes the **Main Body Layer One** pre-assembly steps. Please proceed to the next section: **Main Body Layer Two**.



MAIN BODY LAYER TWO

Layer two of the main body serves as the mounting platform for the azimuth motor. It also houses the “Flip” switch – whose connector was plugged in during the previous section. However, the switch will **NOT** be installed during this section, but rather during the final assembly section.

Please proceed with the following steps to complete the **Main Body Layer Two** pre-assembly.

- 54 Using a 3/32” Allen wrench, insert the set screws into both set screw holes of the **6mm to 6mm set-screw shaft couplers**.



Using the motor that was pre-assembled in step 31, slide the coupler over the motor’s shaft as shown in the image below.

The set screws should be aligned with the shaft’s flat side. Carefully tighten the bottom set screw while adjusting the coupler for a firm fit.

Tip: when inserting the set screws, screw them in so that they protrude very slightly into the coupler’s center hole. This will ensure that the coupler can only be installed with the set screws facing the shaft’s flat side.



- 55 Mount the azimuth motor using (4) **M3 x 6mm Pan Head Screws**. Align the motor as shown in the picture below. **Ensure that the coupler is centered in the opening.**



- 56 Insert one of the **6mm x 60mm D Shafts** into the opening at the top of the **6mm to 6mm set-screw shaft coupler** such that the shaft's flat side is facing the coupler's set screws. Carefully tighten the top set screw while adjusting the coupler for a firm fit.



- 57 This completes the **Main Body Layer Two** pre-assembly steps. Please proceed to the next section: **Main Body Layer Three**.

MAIN BODY LAYER THREE

Layer three of the main body houses the **10k Ω Linear Taper Potentiometer** that transmits the azimuth angle to the PSR-100's microcontroller. It will be mounted along with one of the **45 Tooth Hub-mount Gears**.

Please proceed with the following steps to complete the **Main Body Layer Three** pre-assembly.

- 58 Remove the control nut and top washer from the threaded shaft of the **10kΩ Linear Taper Potentiometer** that was pre-assembled in step 30.

From the underside of **Main Body Layer Three**, insert the threaded shaft into the hole located in the layer's corner. Rotate the potentiometer such that its "tab" will fit into the cutout provided in the layer as shown in the image to the right.

Place the top washer over the threaded shaft and secure the potentiometer using the control nut. Use a 7/16" nut driver to tighten the control nut. **Be careful not to overtighten.**



- 59 Locate the **1/4" Bore Set-screw Hub** and use a 2.5mm Allen wrench to loosely insert its set screw into the hub's threaded receptacle.

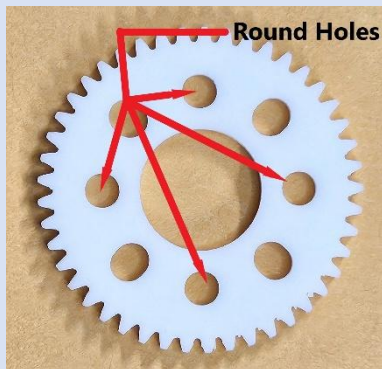

Locate the **45 Tooth Hub-mount Gear**. Identify the round holes in the gear -vs- the elongated holes as shown in the image to the left.

Using (2) M4 x 10mm Pan Head Screws, secure the gear hub via two of the round holes identified above. Use two holes that are on opposite sides of the center hole in the gear.



- 60 Turn the shaft of the azimuth angle potentiometer mounted in step 58 above fully counterclockwise. Mount the azimuth gear/hub assembly to the shaft such that the set screw is facing the wall of the layer as shown in the image.

Tighten the set screw using a 2.5mm Allen wrench.

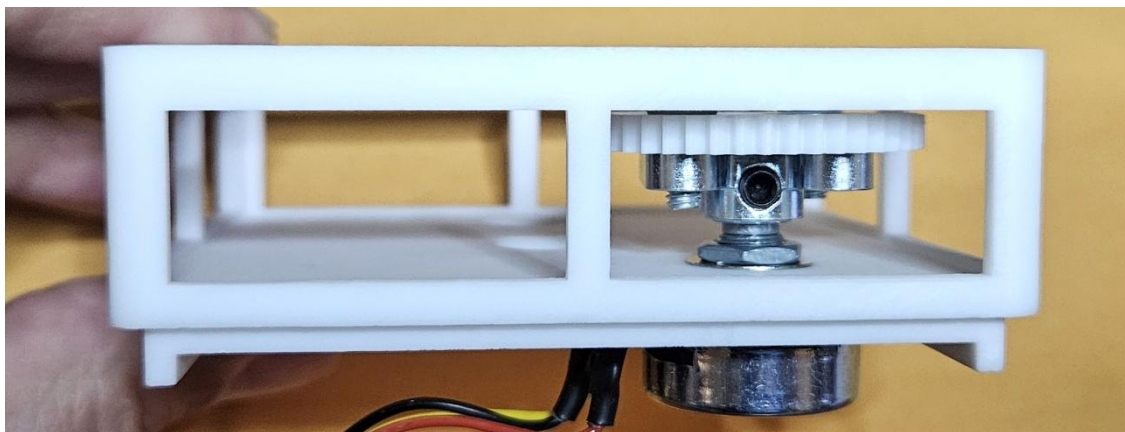

- 61 This completes the **Main Body Layer Three** pre-assembly steps. Please proceed to the next section:
Elevation Motor Mounting Bracket.



ELEVATION MOTOR MOUNTING BRACKET

The elevator mounting bracket holds all the components for elevating the antenna as well as acts as the actual platform for the antenna itself. Therefore, it is connected to the azimuth motor's shaft and rotates on a ball bearing turntable.

- 62 Install one the two **6mm I.D. x 14mm O.D Ball Bearings** on the bracket's vertical arm that has the four small holes meant to secure the elevation motor. Insert the smaller side of the bearing from the outside of the arm and press it towards the center until its outer rim is flush with the bracket.



You will note that there is a recessed edge on the outside of the bracket's opening to receive the rim of the bearing assembly. Please refer to the image to the right for an illustration of the proper installation of this bearing.

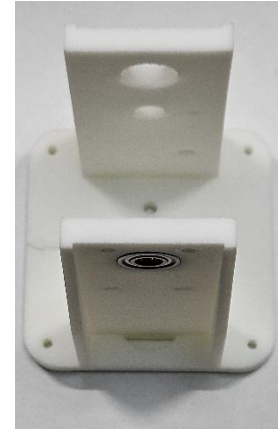

- 63 Insert the shaft of the second **12VDC 2rpm Motors** (the one with no wires yet) into the bearing that was installed in the previous step.



Use the (4) remaining **M3 x 6mm Pan Head Screws** to secure the motor to the bracket. You will have to insert your screwdriver through the upper bearing opening on the other bracket arm in order to reach the upper two screws, and the lower opening (meant for the elevation angle potentiometer) to reach the bottom two screws. Refer to the photo below for guidance:

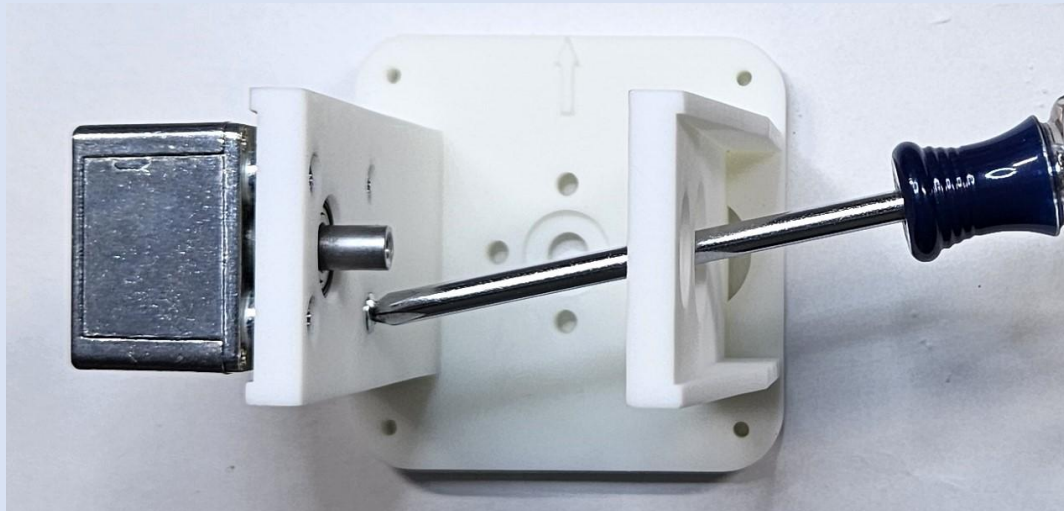

- 64 As you did in step 62, Install the remaining **6mm I.D. x 14mm O.D Ball Bearing** on the bracket's other arm. Insert the smaller side of the bearing from the outside of the arm and press it towards the center until its outer rim is flush with the bracket.



- 65 Prepare the **6mm D-bore Single Sonic Hub** by inserting its (2) socket head screws into their respective threaded receptacles and loosely screwing them in - they will be tightened during the final assembly.

Now, install the hub into the recessed mounting hole in the base of the bracket.

Note: One side of the sonic hub has a raised, circular "key". The recessed portion of the mounting hole is designed to accept this key and ensure the hub is perfectly centered on the bracket.

Use (2) **M4 x 10mm Pan Head Screws** to secure the hub to the bracket. Insert the screws from the bottom of the bracket. The hub's mounting holes are threaded to accept the screws.



- 66 Remove the control nut and top washer from the threaded shaft of the second **10kΩ Linear Taper Potentiometer**.

From the inside of the bracket arm opposite the motor, Insert the threaded shaft into the hole located below the bearing that was installed in step 64. Rotate the potentiometer such that its "tab" will fit into the cutout provided in the bracket arm as shown in the image to the right.

Place the top washer over the threaded shaft and secure the potentiometer using the control nut. Use a 7/16" nut driver to tighten the control nut. **Be careful not to overtighten.**



- 67 Prepare the **6mm D-bore Double Sonic Hub** by inserting its (4) socket head screws into their respective threaded receptacles and loosely screwing them in - they will be tightened during the final assembly.

Now, install the hub into the recessed mounting hole at the end of the **Lower Antenna Mounting Arm**. Install the hub on the side of the arm WITH the raised ribs at its end as shown in the right-hand image below.

Note: One side of the sonic hub has a raised, circular "key". The mounting hole is designed to accept this key and ensure the hub is perfectly centered on the arm.

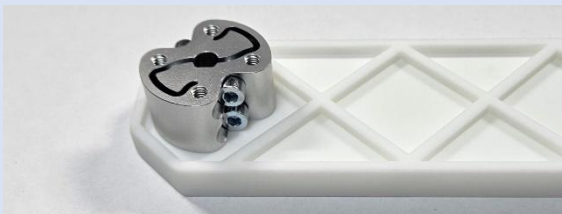

Use (2) **M4 x 10mm Pan Head Screws** to secure the hub to the arm. Insert the screws from the opposite side of the arm. The hub's mounting holes are threaded to accept the screws.

- 68 Mount the elevation arm assembly to the motor shaft by carefully slipping the end with the Sonic hub between the end of the shaft and the elevation angle potentiometer as shown in the image below.
- Align the flat side of the hub's center hole with the flat on the motor's shaft and slide the hub onto the shaft. **Do not tighten the hub's screws yet.**

Important Note: if the arm won't fit when the flat sides are aligned – mainly due to it contacting the bottom of the elevation bracket, you will need to withdraw the arm, remove the hub and rotate it 180°, then remount it. Once the hub has been remounted, retry mounting the arm assembly to the elevation motor's shaft.



- 69 Slide the second **6mm x 60mm D Shaft** through the opening in the **6mm I.D. x 14mm O.D Ball Bearing** mounted in the elevation bracket above the potentiometer and then into the opening in the sonic hub on the elevation arm assembly.

Position the hub so that it is approximately $\frac{1}{8}$ " away from the elevation motor's mounting bracket, then ensure that the shaft is inserted into the hub as far as it can go.

Use a 3mm Allen wrench to tighten the four elevation arm hub's screws. **Do not overtighten the screws.**

- 70 Prepare the **15 Tooth 1/4" Bore Pinion Gear** by inserting its set screw into the threaded hole on the side of the gear using a 2.5mm Allen wrench.

Slide the pinion gear onto the shaft of the elevation potentiometer such that you can still reach the set screw and tighten the set screw using the Allen wrench.

Please refer to the image to the right for the correct alignment of the pinion gear.



- 71 Prepare one of the **30 Tooth, 6mm D-Bore Pinion Gears** by inserting its socket head setscrew into its threaded receptacle and loosely screwing it in so that it just “peeks” inside the gear’s shaft opening.

- 72 Slide the **30 Tooth, 6mm D-Bore Pinion Gear** that you prepared in the previous step onto the end of the elevation shaft as shown in the picture below.

Position the hub so that the gear teeth do not yet mesh with the teeth of the **15 Tooth 1/4" Bore Pinion Gear**. Leave the hub’s socket head screws snug, but not tight. You will be sliding the hub/gear assembly inward to mesh with the pinion gear later on in the **Calibration and Testing** section.

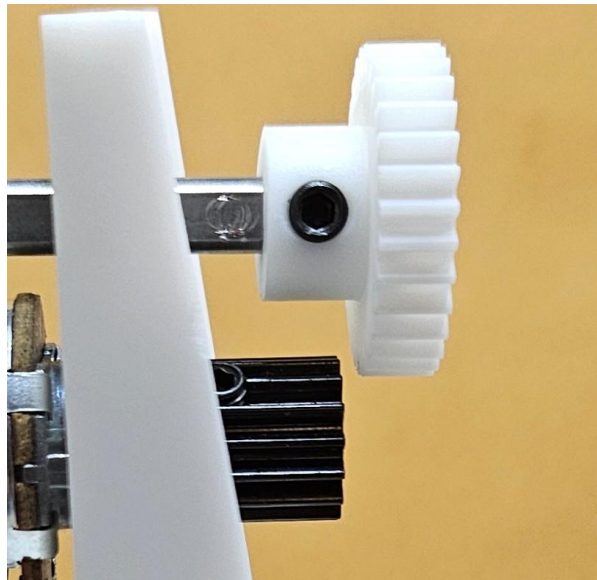

- 73 Mount the **3" Square Ball Bearing Turntable** to the bottom of the using (4) **6-32 x 1/4" pan head machine screws**.

Caution! Do not overtighten the screws. As you can imagine, the 3-D printed threads in the bottom of the elevation bracket can be easily stripped if overtightened.

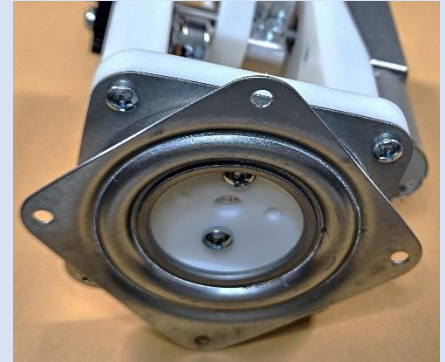

- 74 This completes the **Mechanical Components Pre-assembly** section of the assembly. Please proceed to the next section: **Final Assembly**.

FINAL ASSEMBLY

- 75 Locate the elevation motor cable assembly created in step 26. Plug its connector into the **El Motor** header (**CN2**) on the **PSR-100 Main Board**.

- 76 Locate the elevation potentiometer cable assembly created in step 27. Plug its connector into the **El Pot** header (**CN5**) on the **PSR-100 Main Board**.

- 77 Plug the connector of the azimuth motor cable into the Az Motor header (**CN1**). You will have to position the **Main Body Layer Two** such that the Azimuth Motor's wired end is slightly above the **Main Body Layer One**.

While continuing to hold the **Main Body Layer Two** above the layer one body, route the 2 elevation cable assemblies (installed in the previous 2 steps) through the hole situated next to the flip switch.

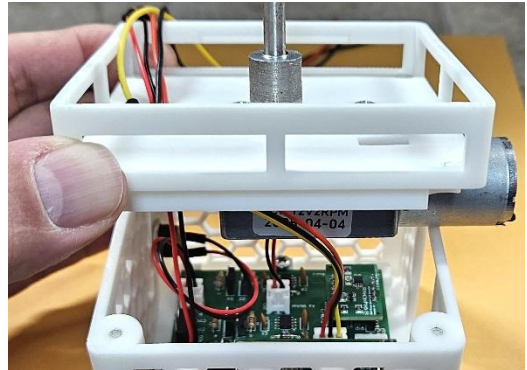

- 78



Carefully tilt the **Main Body Layer Two** so that the azimuth motor will slide into the large opening on the side of the **Main Body Layer One** as shown in the image to the left:

Ensure the cables that were routed in the previous step remain in their hole and that you do not dislodge the azimuth motor's cable assembly from its home in header **CN1**.

Fit the **Main body Layer Two** onto the top of the **Main Body Layer One** and secure it with (4) **6-32 x 1/4" pan head machine screws**. Take care that none of the cable assemblies are pinched between the two layers.

Caution! Do not overtighten the screws. As you can imagine, the 3-D printed threads in the bottom of the can be easily stripped if overtightened.

Refer to the picture on the right for the properly assembled layers one and two.

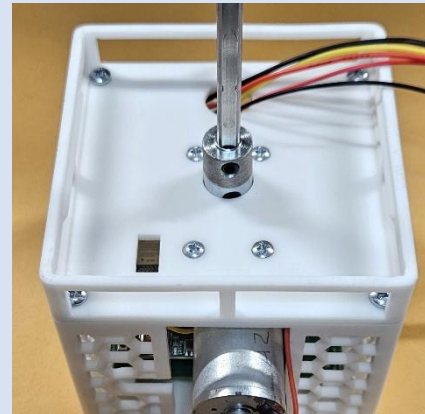

79

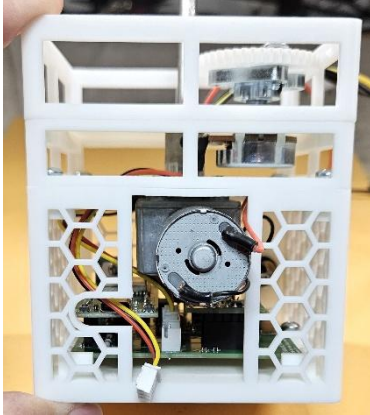

While holding the **Main Body Layer Three** above the layer two body, route the 2 elevation cable assemblies that are coming from layer one through the corresponding routing hole in the floor of layer three.

Likewise, route the azimuth potentiometer cable assembly through the rectangular hole provided in the floor of layer two.

Route the cable assembly as shown in the photo to the left.

Snap the Main Body Layer Three to the Main Body Layer Two.

80



Use a pair of needle nose pliers to plug the azimuth potentiometer cable assembly into the Az Pot header (**CN4**). Refer to the image below for guidance.



- 81 If not already done so, prepare the **30 Tooth, 6mm D-Bore Pinion Gear** by inserting its socket head setscrew into its threaded receptacle and loosely screwing it in.

Slide the gear onto the azimuth shaft and gently mate its teeth with those of the azimuth potentiometer gear. Continue to slide the gear towards the azimuth motor until it contacts the shaft coupler that was installed in step 54. The teeth of the two gears should no longer be engaged. This is normal for now – this pinion gear will be raised and secured during the **Calibration and Testing** section.

Please refer to the image on the right for guidance.



The purpose of the next seven steps is to set up the rotor assembly so that you can temporarily position the azimuth motor's shaft so that it will point the antenna's mounting arm at zero degrees. From this position, the rotor will only be allowed to rotate clockwise as it is a hard, mechanical stop for any further counterclockwise movement.

Once in this position, we will continue with the normal final assembly steps starting with the routing of the elevation wiring assemblies around the azimuth shaft to ensure they do not become wrapped too tightly around the shaft.

- 82 Temporarily route the cable assemblies through one of the side windows of the **Main Body Layer Three** as shown below:

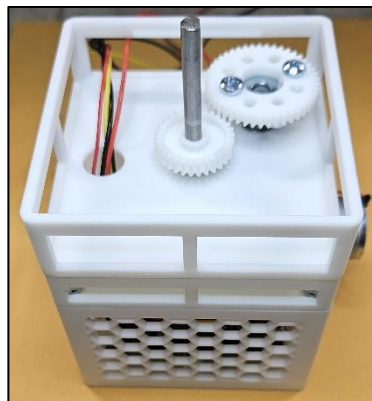

This is to allow the temporary installation of the **Main Body Top Plate**.

- 83 Temporarily place the **Main Body Top Plate** onto the **Main Body Layer Three** by orienting it as shown below, then snapping it onto the layer three body.



- 84 Orient the hub opening in the base of the **Elevation Motor Mounting Bracket** so that its flat side is aligned with the flat side of the azimuth motor shaft protruding from the **Main Body Top Plate**.
- Gently slide the hub onto the azimuth motor shaft – loosen the hub's screws if necessary. The **Elevation Motor Bracket** assembly should now be sitting on the **Main Body Top Plate**. Refer to the photo on the left.



- 85 Apply 12VDC to the rotor's DC power receptacle and wait a few seconds for the rotor's MCU to fully boot and connect to WiFi.
- As in step 38, open your browser and navigate to the rotor's Home page, then click on the Calibration button. Once on the calibration page, click the Next Step button until you're on **Step 3: Azimuth 0° (North)**

- 86 Note the current voltage being displayed. Use your finger to slowly rotate the azimuth potentiometer's 45 tooth gear until the angle reads about 1.00 Volts.
- Note: the reason for this step is to fool the rotor's microcontroller that it is safe to manually rotate the azimuth motor in either direction.**

- 87 Use the **AZ CW** and/or the **AZ CCW** buttons to rotate the Elevation Motor Mounting Bracket so that the raised arrow on the upper side of the bracket's base is pointing to the center of the side of the main body that contains all the toggle switches. Please refer to the image to the right for guidance:

Note: This is considered the zero degree location.

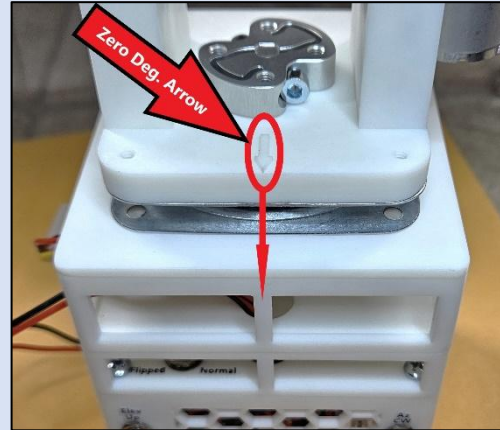

- 88 Remove the power cable for now.

The azimuth shaft positioning steps are now complete – please continue with the remainder of the Final Assembly.

- 89 Carefully remove the **Elevation Motor Mounting Bracket** from the **Main Body Top Plate** by carefully sliding the bracket's base hub off of the azimuth motor's shaft.

- 90 Remove the **Main Body Top Plate** from the **Main Body Layer Three** and set it close to the layer so that the elevation wiring assemblies can be routed through their top plate channel.

Route all five wires – first, between the bottom of the top plate and the gear protection shelf, then by clipping the wires inside the retaining clip as shown in the photo to the right.

Flip the Main Body Top Plate over and press it onto the Main Body Layer Three until it snaps into place.

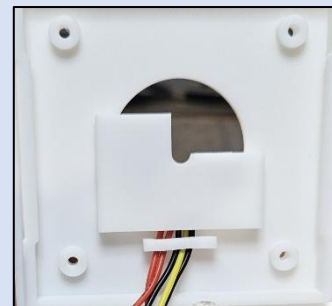

- 91 Loosen the four **6-32 x 1/4"** pan head machine screws attaching the **3" Square Ball Bearing Turntable** to the base of the **Elevation Motor Mounting Bracket** in order to provide enough room to snake the elevation motor and elevation angle potentiometer wiring assemblies into their respective channels – an extra **1/8"** should be sufficient.

92 Route the elevation motor wires as shown in the photos below:

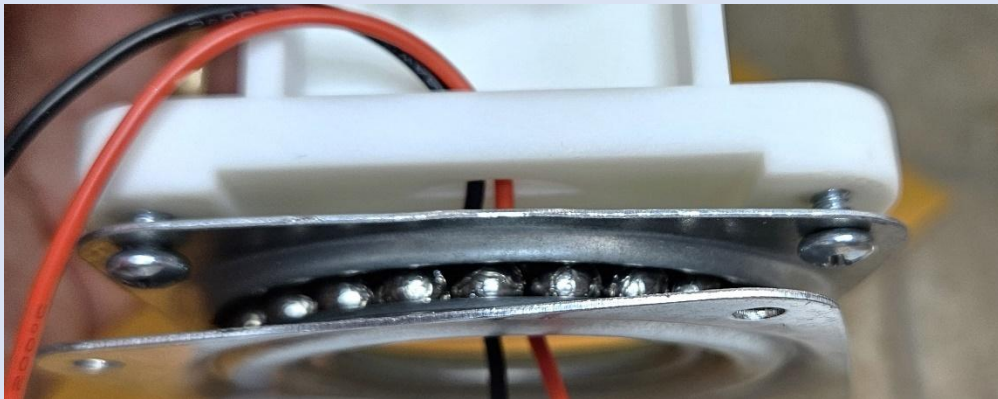

Note: You can easily distinguish between the elevation motor wires and the black and red elevation potentiometer wires – the motor wires will be longer than the potentiometer wires.

Tip: Putting a small bend in the end of each wire will make it easier to snake the wire into the opening provided in the Elevation Motor Mounting Bracket's base.

93 Route the azimuth potentiometer wires as shown in the image below:



Tip: Putting a small bend in the end of each wire will make it easier to snake the wire into the opening provided in the Elevation Motor Mounting Bracket's base.

- 94 Retighten the (4) **6-32 x 1/4"** pan head machine screws attaching the **3" Square Ball Bearing Turntable** to the base of the **Elevation Motor Mounting Bracket**.

Caution! Do not overtighten the screws. As you can imagine, the 3-D printed threads in the bottom of the can be easily stripped if overtightened.

- 95 Ensure the elevation wires are routed counterclockwise around the shaft as shown in the picture below.

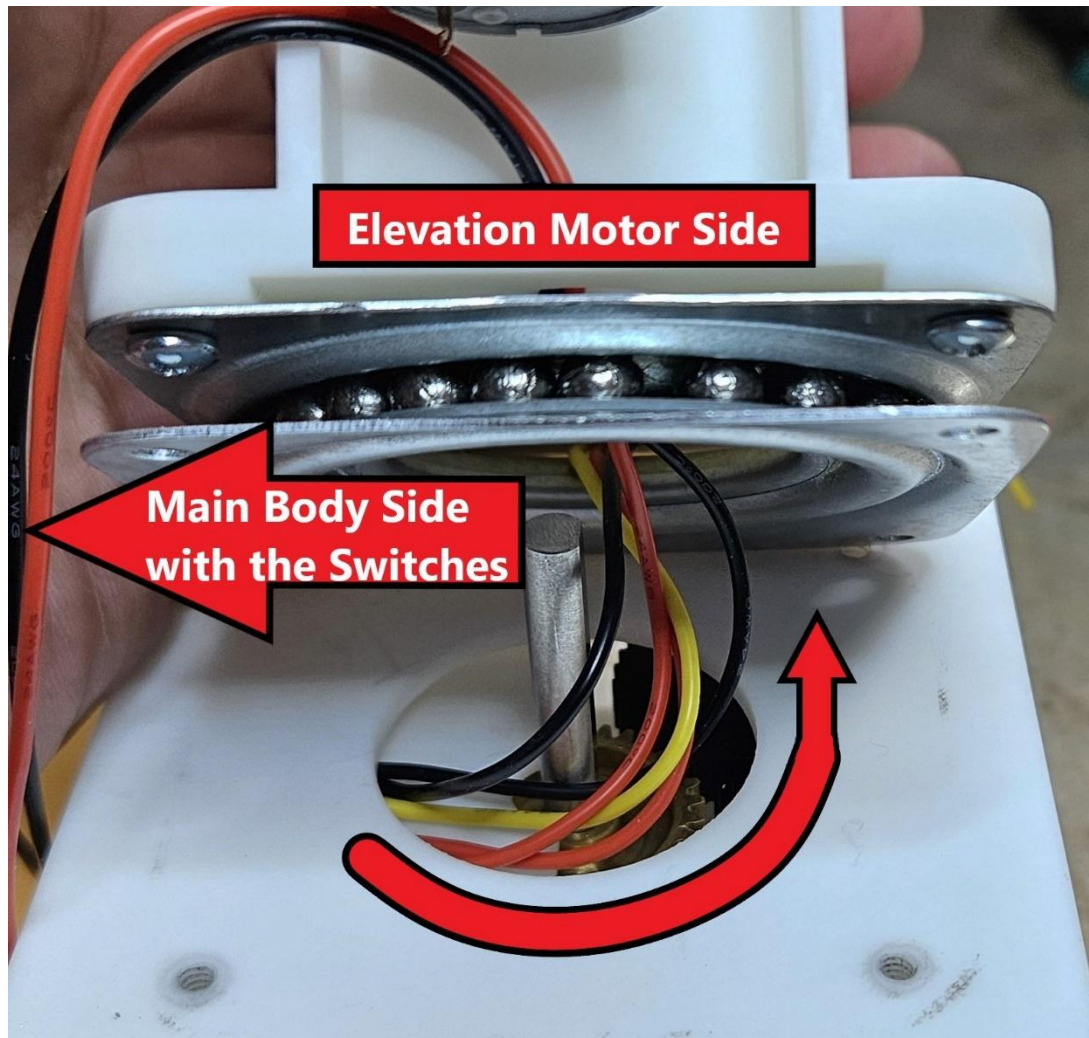

Also ensure that the excess slack has been pulled out of the wires so that they appear as they do above.

- 96 Slide the **Elevation Motor Mounting Bracket's** base hub onto the azimuth motor shaft while ensuring the elevation motor wires are not being pinched by the turntable.

Use a 3mm Allen wrench to tighten the two socket head screws on the bracket's base hub. Put a slight downward pressure while tightening the screws to ensure that the Main Body layers are held tightly together.

- 97 Once again, apply 12VDC to the rotor's DC power receptacle and wait a few seconds for the rotor's MCU to fully boot and connect to WiFi.

As in step 38, open your browser and navigate to the rotor's Home page, then click on the Calibration button. Once on the calibration page, click the Next Step button until you're on **Step 3: Azimuth 0° (North)**

use the **AZ CW** and/or the **AZ CCW** buttons to rotate the **Elevation Motor Mounting Bracket** as needed to allow you to secure the turntable to the **Main Body Top Plate**. Use (4) **6-32 x ¼"** pan head machine screws.

Caution! Do not overtighten the screws. As you can imagine, the 3-D printed threads in the Main Body Top Plate can be easily stripped if overtightened.

Once finished, use the **AZ CW** and/or the **AZ CCW** buttons to return the **Elevation Motor Mounting Bracket** to the zero-degree location as was done in step 87.

- 98 Remove the 12VDC power source from the power receptacle.

- 99 Route the elevation potentiometer wires through the small hole below and to the left of the elevation potentiometer's shaft as shown in the image to the right.

Leave a little slack in wires when pulling them through the opening.

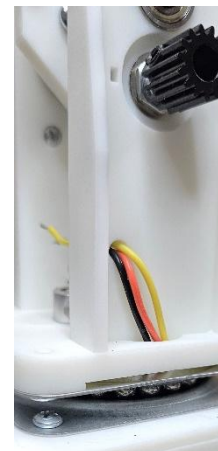

- 100

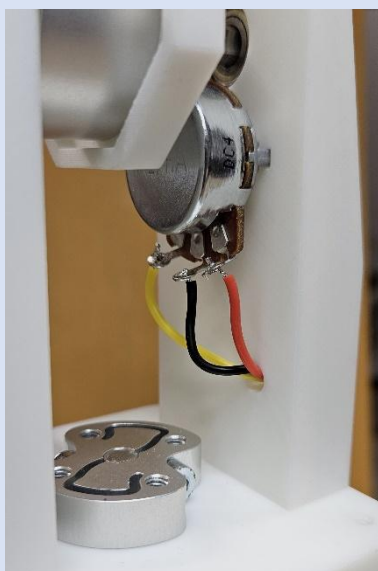

Prepare the elevation potentiometer wires by trimming them to a length where they can easily reach the elevation potentiometer's solder lugs but won't create a large "loop" when hooked up. Discard the wire pieces that you removed.

Strip about ¼" of insulation off of each wire and twist and tin the exposed wires.

Connect each wire to its respective solder lug on the elevation potentiometer as shown in the image to the left. Trim any excess wire after soldering.

101



Prepare the elevation motor wires by trimming them to a length where they can easily reach the elevation motor's solder lugs but won't create a large "loop" when hooked up. Discard the wire pieces that you removed.

Strip about $\frac{1}{4}$ " of insulation off of each wire and twist and tin the exposed wires.

Cut two $\frac{1}{4}$ " pieces of heat shrink tubing

Slide a piece of heat shrink tubing over each wire, then connect and solder each wire to its respective solder lug on the elevation motor as shown in the image to the left. The **RED** wire connects to the solder lug with the red spot next to it. The **BLACK** wire to the other solder lug.

Trim any excess wire after soldering, then slide the heat shrink tubing over the solder lug and use a heat gun to shrink the tubing.

102



Apply 12VDC to the rotor's DC power receptacle and wait a few seconds for the rotor's MCU to fully boot and connect to WiFi.

As in step 38, open your browser and navigate to the rotor's Home page, then click on the Calibration button. The calibration page should be on **Step 1: Elevation 0° (Horizontal)**

103



Note the current voltage being displayed. Use your finger to slowly rotate the elevation potentiometer's 15 tooth gear until the angle reads about 1.00 Volts.

Note: the reason for this step is to fool the rotor's microcontroller that it is safe to manually rotate the elevation motor in either direction.

104



Use the **EL UP** and/or **EL DOWN** buttons to rotate the **Lower Antenna Mounting Arm** so that it is straight up and down (zero degrees elevation).

105



This completes the physical assembly of the PSR-100 Mk2 Portable Satellite Antenna Rotor.

Keep power applied to the rotor and rotor's web page active.

Please proceed to the next section: **Calibration and Testing**

CALIBRATION AND TESTING

This is the final section of the step-by-step assembly instructions.

In this section you will be using the PSR-100's Calibration Web Page to perform the gear and potentiometer alignment procedures for the azimuth and elevation gear trains. You will also be using it to calibrate the rotor's azimuth and elevation angles as being transmitted by the respective potentiometers.

ELEVATION POTENTIOMETER

Please perform the following steps to complete the elevation potentiometer installation as well as its calibration.

- 106 If your browser is not still on the rotor's calibration page, navigate back to it now.
- The calibration procedure is a guided, step-by-step process that will ensure that both the elevation and azimuth gear trains provide the most accurate angle measurements
- Ensure that the calibration page has opened at **Step 1: Elevation 0° (Horizontal)**. If not, use the **Previous Step** button. The page's center pane should appear as shown in the image below:

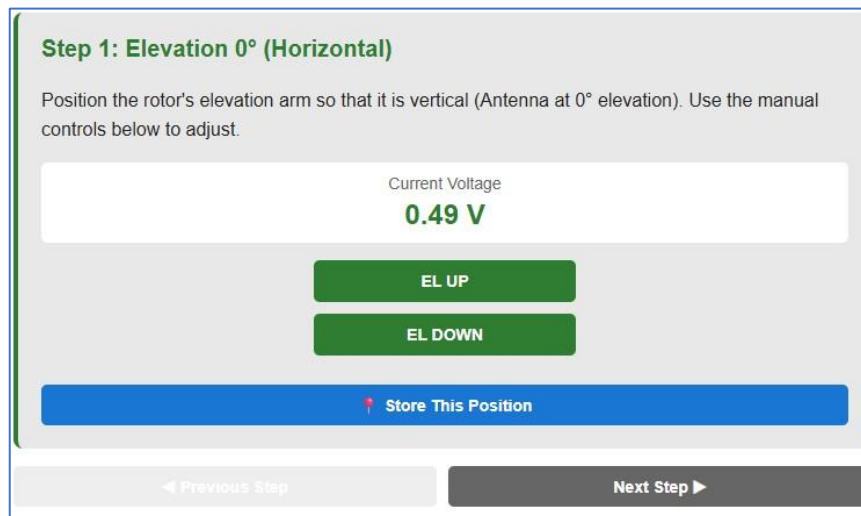

- 107 Ensure that the **Lower Antenna Mounting Arm** is still straight up and down (zero degrees elevation) as performed in step 104. If not, use **EL UP** and/or the **EL DOWN** buttons as appropriate to achieve this.
- Use your fingers to adjust the elevation potentiometer so that the **Current Voltage** value as seen in the center of the Step 1 pane is between 0.30 and 0.50.

108

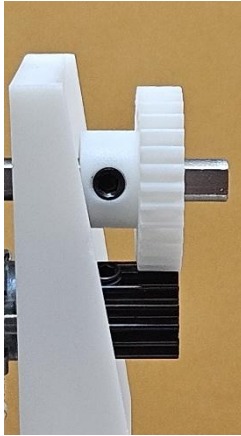

Slide the **30 Tooth, 6mm D-Bore Pinion Gear** inward to carefully mesh with the elevation potentiometer pinion gear. The gear/hub assembly should be fully engaged with the pinion gear as shown in the image to the left.

Caution: Ensure that the elevation hub/gear assembly has not been slid too far as this may cause it to interfere with the pinion gear's set screw.

109 Use a 2.5mm Allen wrench to tighten the socket head screw on the elevation gear hub.



Caution! Do not overtighten the set screw as the 3D printed threads can easily be stripped. The screw only needs to be snug enough to prevent the gear from sliding back and forth since the D-shaft will prevent it from spinning.

110 Ensure the **Current Voltage** value still reads within the range between 0.30 and 0.50. Redo the previous 3 steps if the voltage has strayed outside this range.



111 Click the **Store This Position** button and ensure the stored message similar to the one shown below is displayed.



✓ EL 0° stored successfully!
Voltage: 0.49V

Once you receive the message, click the **Next Step** button to move to step two of the guided calibration process.

112 As instructed in the **Step 2: Elevation 90° (Vertical)** text, use **EL UP** and/or the **EL DOWN** buttons as appropriate to move the **Lower Antenna Mounting Arm** so that it is at 90 degrees (Horizontal).



113 Click the **Store This Position** button to store the **Current Voltage** reading.



The **EL 90° stored successfully** message should appear shortly after clicking the **Store This position** button.

Once you receive the message, click the **Next Step** button to move to the azimuth portion of the guided calibration process.

114 Please proceed with the next section: **Azimuth Potentiometer**.



AZIMUTH POTENTIOMETER

Please perform the following steps to complete the azimuth potentiometer installation as well as its calibration.

- 115 The calibration procedure should now be at **Step 3: Azimuth 0° (North)** as shown in the image below:

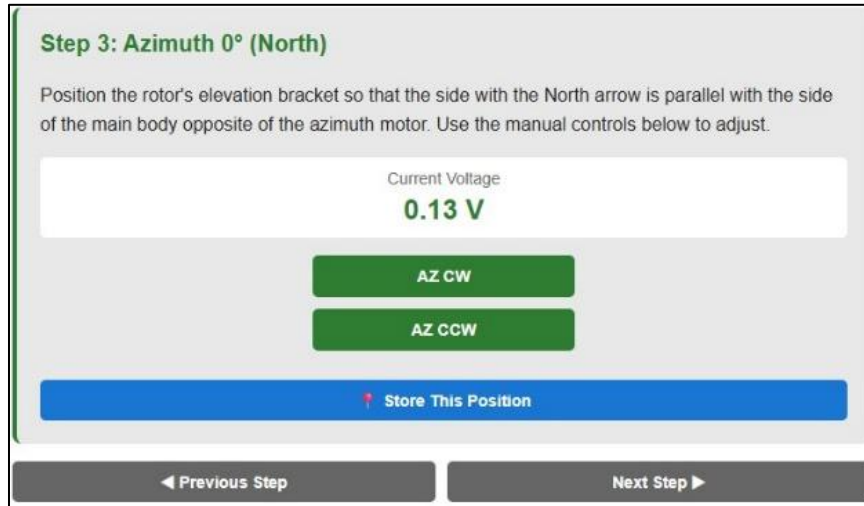

- 116 Use your finger to adjust the azimuth pot gear so that the **Current Voltage** value is between 0.13 and 0.25.



- 117 Slide the azimuth pinion gear up so that its teeth mesh those of the azimuth potentiometer gear's teeth.



- 118 While holding the pinion gear in position, use a 2.5mm Allen Wrench to tighten its socket head set screw.



Caution! Do not overtighten the set screw as the 3D printed threads can easily be stripped. The screw only needs to be snug enough to prevent the gear from sliding up and down since the D-shaft will prevent it from spinning.

- 119 Ensure the **Current Voltage** value still reads within the range between 0.13 and 0.25. Redo the previous 3 steps if the voltage has strayed outside this range.



- 120 Click the **Store This Position** button and ensure the stored message similar to the one shown below is displayed.



✓ AZ 0° stored successfully!
Voltage: 0.13V

Once you receive the message, click the **Next Step** button to move to step four of the guided calibration process.

- 121 As instructed in the Calibration Procedure's **Step 4: Azimuth 90° (East)** text, use the **AZ CW** and/or the **AZ CCW** buttons as appropriate to rotate the **Elevation Motor Mounting Bracket** so that it is at 90 degrees.

Tip: To easily judge the 0, 90, 180, 270 and 360 degree positions, line up the edges of the upper and lower parts of the turntable as shown in the image below.



- 122 Click the **Store This Position** button to store the 90-degree **Current Voltage** value.
 The AZ 90° stored message should appear shortly after clicking the **Store This Position** button.
Once you receive the message, click the **Next Step** button to move to step five of the guided calibration process.
- 123 As instructed in the Calibration Procedure's **Step 5: Azimuth 180° (South)** text, use the **AZ CW** and/or the **AZ CCW** buttons as appropriate to rotate the **Elevation Motor Mounting Bracket** so that it is at 180 degrees.
- 124 Click the **Store This Position** button to store the 180-degree **Current Voltage** value.
 The AZ 180° stored message should appear shortly after clicking the **Store This Position** button.
Once you receive the message, click the **Next Step** button to move to step six of the guided calibration process.
- 125 As instructed in the Calibration Procedure's **Step 6: Azimuth 270° (West)** text, use the **AZ CW** and/or the **AZ CCW** buttons as appropriate to rotate the **Elevation Motor Mounting Bracket** so that it is at 270 degrees.
- 126 Click the **Store This Position** button to store the 270-degree **Current Voltage** value.
 The AZ 270° stored message should appear shortly after clicking the **Store This Position** button.
Once you receive the message, click the **Next Step** button to move to step seven of the guided calibration process.
- 127 As instructed in the Calibration Procedure's **Step 7: Azimuth 360° (North Again)** text, use the **AZ CW** and/or the **AZ CCW** buttons as appropriate to rotate the **Elevation Motor Mounting Bracket** so that it is at 360 degrees.

- 128 Click the **Store This Position** button to store the 360-degree **Current Voltage** value.
 The AZ 360° stored message should appear shortly after clicking the **Store This Position** button.

- 129 Ensure that the stored voltages are similar to the ones shown in the **Stored Calibration Values** pane shown below:



Your values will vary slightly, but they should still progress similarly in value for each successive angle. If they don't, such as:

- Identical values for different angles
- A greater value for a lesser angle (or vice-versa)

Go back to the respective steps for the offending angle and redo that step.

- 130 Congratulations! You have completed the assembly of your PSR-100 Portable Satellite Antenna Rotor. Please proceed to the next, and final, section: **Live Testing**.

LIVE TESTING

This section will run through several tests to ensure that the rotor's calibration is within specs. It will also test the "Flip" mode that will move the physical CW stop to the 180-degree position and the CCW physical stop to the 181-degree position.

Please refer to the image below while performing the next steps:

The interface shows control fields for Azimuth (0-359) and Elevation (0-90), both set to 0. Buttons for 'Execute', 'STOP!', and 'Park' are visible. To the right, 'Park Az' and 'Park El' are also set to 0, with a 'Save Park' button. Below is the 'System Status' pane:

System Status					
UPTIME 23:38:06 Power On	WIFI IP 192.168.0.160	SIGNAL -38 dBm	THEME Light Toggle	FLIPPED No Toggle	MOVEMENT AZ: Idle EL: Idle

- 131 Navigate your web browser to the rotor's Home page and enter **180** in the **Az (0-359)** field and **45** in the **El (0-90)** field, then click the Execute button.

Note that the rotor begins moving to these new azimuth and elevation angles.

- 132 Enter **270** in the **Az (0-359)** field and **90** in the **El (0-90)** field, then click the Execute button.

Note that the rotor begins moving to these new azimuth and elevation angles.

- 133 Enter **360** in the **Az (0-359)** field and **45** in the **El (0-90)** field, then click the Execute button.
- While the motors are still moving, click the **Stop** button and ensure both motors stop immediately.
- 134 Note the **Park Az** and **Park El** angles – the defaults are 0° Az and 0° El. Click the **Park** button.
- Note that the rotor moves to these angles.
- 135 Click the **Toggle** button in the **Flipped** card of the **System Status** pane at the bottom of the **Home** page.
- Note that the Flipped status changes to **Yes** and the rotor immediately starts to rotate clockwise to the (formerly) **180** degree position. Also note that the Azimuth angle display tracks from **180** degrees to **360** degrees but then displays **0** degrees once movement stops. While in flipped mode the new **0** degree position is **180** degrees opposite that of Normal mode.
- Flipped mode is used when you know that the satellite being tracked will be pass north of your position. Normally this would require the rotor to turn backwards through 360 degrees when transitioning between 0 degrees and 360 degrees due to the physical stop. Flipped mode allows the rotor to seamlessly transition since the physical stop has been moved to the 180 degree position.
- 136 While in flipped mode, re-run the angle tests performed in steps 131 through 134.
-
- 137 Go back to normal mode by once again clicking the **Toggle** button in the **Flipped** card of the **system status** pane at the bottom of the **Home** page.
- Note that the rotor immediately starts to rotate counterclockwise to the original **0** degree position. Also note that the Azimuth angle display tracks from **180** degrees to **0**.
- 138 Your PSR-100 is now ready for use.
-

TROUBLESHOOTING

Before reviewing Table 4 below for possible solutions to your problem, please take time to inspect the following items carefully and thoroughly:

- **Solder Joints** – Bad solder joints are the single most common cause of non-working electronics projects.
- **Correct diode polarity** – Make sure that the white (or black) band is pointing in the correct direction.
- **Correct voltage regulator orientation** – Ensure their tabs match their circuit board outlines.
- **JST XH PCB header orientation** – Ensure all JST XH headers (CN1-CN5) are oriented as indicated by their circuit board outlines as well as the assembly instructions.
- **N-channel power MOSFET orientation** - Ensure their tabs match their circuit board outlines (Q1-Q8).
- **12VDC 2rpm Motor wiring** – Ensure the red wire is connected to the solder lug next to the red dot.
- **AZ and EL angle potentiometer wiring** – Ensure that the correct color wires are connected to their respective solder lugs as shown in their assembly steps (step **30** for AZ; step **100** for EL)
- **PSR-100 Microcontroller Module (MCU) installed correctly** – Ensure that the MCU board’s WiFi antenna is situated above Q5 and Q7.
- **Analog to Digital Converter (ADC) Module Installed correctly** – Ensure that pin 1 on the module mates up with Pin 1 on the circuit board’s header H3.

When reviewing the possible solutions in Table 4, all measurements are made between the point named in the text and the power connector’s ground (black wire) unless otherwise noted in the text. Likewise, any test that requires applying a voltage will be made referenced to this same ground.

Table 4 - Troubleshooting Matrix

Symptom	Possible Solutions	
The PSR-100 Microcontroller’s red power LED does not illuminate	Check for: <ul style="list-style-type: none"> • +5VDC on Pin 1 of the MCU’s H2 (see image below) 	If measurement is bad: <ul style="list-style-type: none"> • Bad solder joint on either the MCU’s male H2 header, or the Main Board’s female H2 header. • Bad +5VDC Linear Regulator (U2)
	<ul style="list-style-type: none"> • Above measurement is good 	<ul style="list-style-type: none"> • Faulty MCU Board – Contact WA4MCMkits

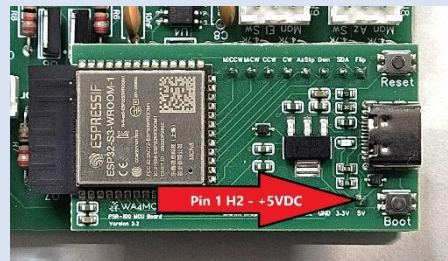

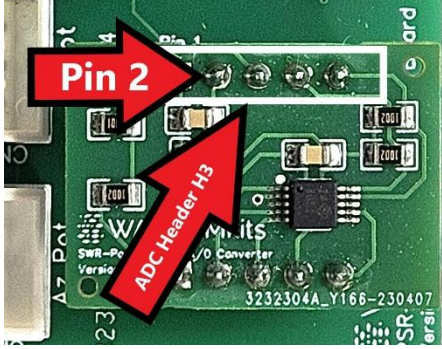
<p>The rotor's Home page doesn't display the Azimuth and Elevation angle display windows.</p>	<p>Check for:</p>	<p>If measurement is bad:</p>
	<ul style="list-style-type: none"> Red Power LED on Microcontroller Module is illuminated 	<ul style="list-style-type: none"> See troubleshooting step above
	<ul style="list-style-type: none"> ADC module is plugged in correctly – Pin 1 on the module matches Pin on the Main Board 	<ul style="list-style-type: none"> Realign the ADC Module
	<ul style="list-style-type: none"> Check for +5VDC on Pin 2 of the ADC Module's H3 (see image below for ADC pins) 	<ul style="list-style-type: none"> Bad solder joint on either the ADC Module's' male H3 header, or the Main Board's female H3 header. Bad +5VDC Linear Regulator (U2)
	<ul style="list-style-type: none"> Remove power and confirm continuity between Pin 4 of the ADC Module's H3 and Pin 4 of the MCU Module's H2 (SCL) (see image below for MCU pins) 	<ul style="list-style-type: none"> Bad solder joint on either the ADC Module's' male H3 header, or the Main Board's female H3 header. Bad solder joint on either the MCU's male H2 header, or the Main Board's female H2 header.
<ul style="list-style-type: none"> Remove power and confirm continuity between Pin 5 of the ADC Module's H3 and Pin 2 of the MCU Module's H1 (SDA) (see image below for MCU pins) 	<ul style="list-style-type: none"> Bad solder joint on either the ADC Module's' male H3 header, or the Main Board's female H3 header. Bad solder joint on either the MCU's male H1 header, or the Main Board's female H1 header. 	

Symptom	Possible Solutions
	<div data-bbox="581 310 1344 751" data-label="Image"> </div> <div data-bbox="500 772 1386 848" data-label="List-Group"> <ul style="list-style-type: none"> <li data-bbox="500 772 711 806">• All checks pass <li data-bbox="1019 772 1386 848">• Faulty ADC Module – Contact WA4MCMkits </div>

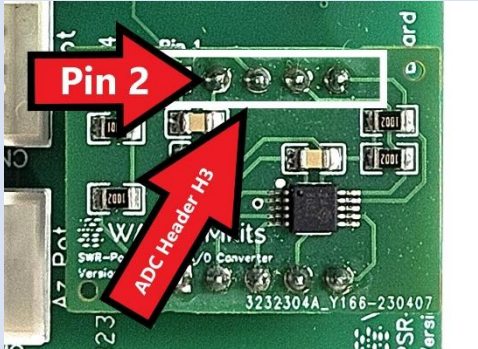
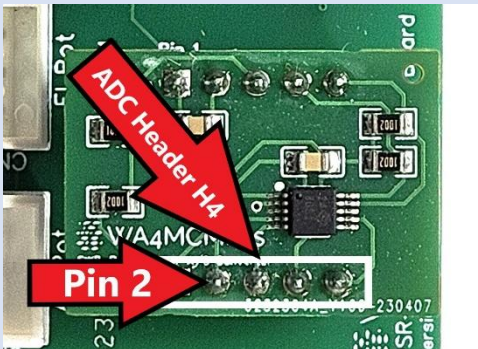
Symptom	Possible Solutions	
<p>The azimuth voltage displayed on step 3 of the calibration page doesn't change with the rotation of the azimuth potentiometer.</p>	<p>Check for:</p> <ul style="list-style-type: none"> • ADC module is plugged in correctly – Pin 1 on the module matches Pin on the Main Board 	<p>If measurement is bad:</p> <ul style="list-style-type: none"> • Realign the ADC Module
	<ul style="list-style-type: none"> • Check for +5VDC on Pin 2 of the ADC Module's H3 (see image below for ADC pins) 	<ul style="list-style-type: none"> • Bad solder joint on either the ADC Module's male H3 header, or the Main Board's female H3 header. • Bad +5VDC Linear Regulator (U2)
	<ul style="list-style-type: none"> • Remove power and measure 60kΩ between Pin 2 of the ADC Module's H4 and the center solder lug of the azimuth potentiometer 	<ul style="list-style-type: none"> • Bad solder joint on either the ADC Module's male H4 header, any of the CN4 (Az Pot) pins, or the Azimuth potentiometer's solder lugs. • Bad solder joints on either R10 (220kΩ, or R11 (1MΩ)
	<ul style="list-style-type: none"> • All checks pass 	<ul style="list-style-type: none"> • Faulty ADC Module – Contact WA4MCMkits
<p>The elevation voltage displayed on step 1 of the calibration page doesn't change with the rotation of the elevation potentiometer.</p>	<p>Check for:</p> <ul style="list-style-type: none"> • ADC module is plugged in correctly – Pin 1 on the module matches Pin on the Main Board 	<p>If measurement is bad:</p> <ul style="list-style-type: none"> • Realign the ADC Module

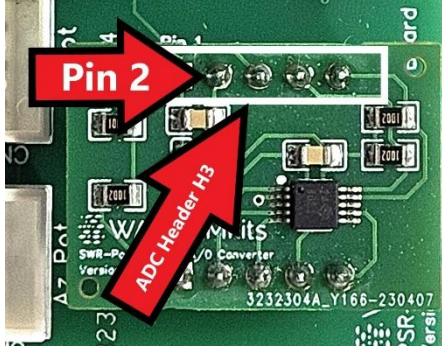
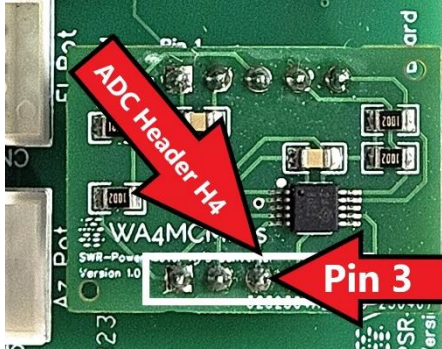
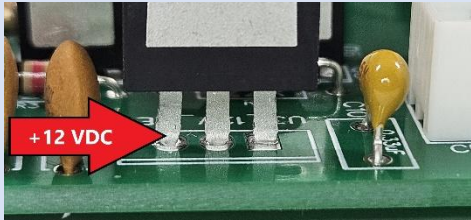
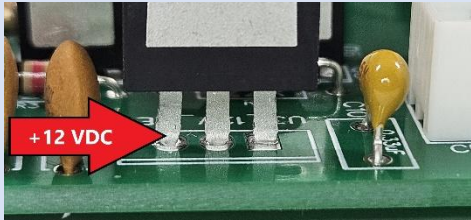
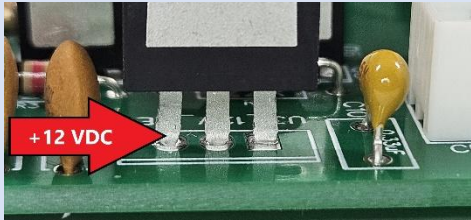
Symptom	Possible Solutions							
	<ul style="list-style-type: none"> Check for +5VDC on Pin 2 of the ADC Module's H3 (see image below for ADC pins) 	<ul style="list-style-type: none"> Bad solder joint on either the ADC Module's' male H3 header, or the Main Board's female H3 header. Bad +5VDC Linear Regulator (U2) 						
	<ul style="list-style-type: none"> Remove power and measure 60kΩ between Pin 3 of the ADC Module's H4 and the center solder lug of the elevation potentiometer 	<ul style="list-style-type: none"> Bad solder joint on either the ADC Module's' male H4 header, any of the CN5 (EI Pot) pins, or the Azimuth potentiometer's solder lugs. Bad solder joints on either R9 (220kΩ, or R12 (1MΩ) 						
	<ul style="list-style-type: none"> All checks pass 	<ul style="list-style-type: none"> Faulty ADC Module – Contact WA4MCMkits 						
<p>The azimuth motor does not turn at all.</p>	<table border="1"> <thead> <tr> <th data-bbox="479 1365 1003 1423">Check for:</th> <th data-bbox="1003 1365 1440 1423">If measurement is bad:</th> </tr> </thead> <tbody> <tr> <td data-bbox="479 1423 1003 1776"> <ul style="list-style-type: none"> +12VDC on the output pin of the linear voltage regulator U3_12V_REG (see image below)  </td> <td data-bbox="1003 1423 1440 1776"> <ul style="list-style-type: none"> Bad solder on voltage regulator pin(s) Damaged circuit board trace(s) Voltage regulator installed backwards Faulty voltage regulator </td> </tr> <tr> <td data-bbox="479 1776 1003 1890"> <ul style="list-style-type: none"> The above reading is good </td> <td data-bbox="1003 1776 1440 1890"> <ul style="list-style-type: none"> Perform the checks for the azimuth motor CW and CCW movements </td> </tr> </tbody> </table>		Check for:	If measurement is bad:	<ul style="list-style-type: none"> +12VDC on the output pin of the linear voltage regulator U3_12V_REG (see image below) 	<ul style="list-style-type: none"> Bad solder on voltage regulator pin(s) Damaged circuit board trace(s) Voltage regulator installed backwards Faulty voltage regulator 	<ul style="list-style-type: none"> The above reading is good 	<ul style="list-style-type: none"> Perform the checks for the azimuth motor CW and CCW movements
Check for:	If measurement is bad:							
<ul style="list-style-type: none"> +12VDC on the output pin of the linear voltage regulator U3_12V_REG (see image below) 	<ul style="list-style-type: none"> Bad solder on voltage regulator pin(s) Damaged circuit board trace(s) Voltage regulator installed backwards Faulty voltage regulator 							
<ul style="list-style-type: none"> The above reading is good 	<ul style="list-style-type: none"> Perform the checks for the azimuth motor CW and CCW movements 							

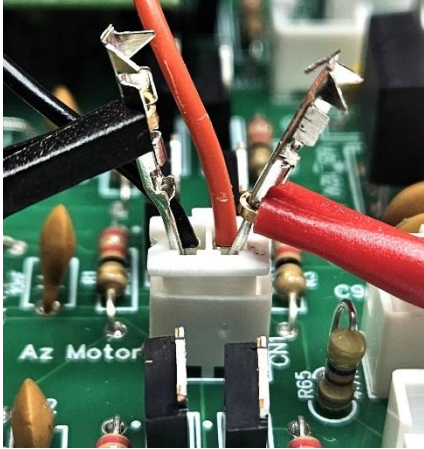
Symptom	Possible Solutions	
<p>The azimuth motor does not turn clockwise (CW).</p>	<p>Check for: If measurement is bad:</p>	
	<p>The following measurement is performed with the black multimeter lead connected to the black wire of CN1 and the red multimeter lead connected to the red wire of CN1. Refer to the following image for one possible method for accomplishing this:</p> <div style="text-align: center;">  </div>	
	<ul style="list-style-type: none"> • About +11.7VDC while activating the manual azimuth switch in the CW direction (toggle towards the red wire) 	<ul style="list-style-type: none"> • Bad solder on CN1 pins (Az Motor) • Q1 and/or Q2 and/or Q3 and/or Q4 installed backwards • Bad solder joints on any of the following components: Q1-Q4, R1-R4, D1, D2, C1, C2, C5, C6 • Either of the following components are faulty; Q1-Q4, D1, D2 • U1 is faulty – contact WA4MCMkits
<ul style="list-style-type: none"> • The above reading is good 	<ul style="list-style-type: none"> • Bad solder connection for the motor wiring to either motor solder lug. • Bad Motor 	

Symptom	Possible Solutions	
<p>The azimuth motor does not turn counterclockwise (CCW).</p>	<p>Check for: If measurement is bad:</p>	
	<p>The following measurement is performed with the black multimeter lead connected to the black wire of CN1 (Az Motor) and the red multimeter lead connected to the red wire of CN1 (Az Motor). Refer to the following image for one possible method for accomplishing this:</p> <div data-bbox="750 485 1172 930" style="text-align: center;"> </div>	
	<ul style="list-style-type: none"> • About -11.7VDC while activating the manual azimuth switch in the CCW direction (toggle towards the yellow wire) 	<ul style="list-style-type: none"> • Bad solder on CN1 pins (Az Motor) • Q1 and/or Q2 and/or Q3 and/or Q4 installed backwards • Bad solder joints on any of the following components: Q1-Q4, R1-R4, D1, D2, C1, C2, C5, C6 • Either of the following components are faulty; Q1-Q4, D1, D2 • U2 is faulty – contact WA4MCMkits
<ul style="list-style-type: none"> • The above reading is good 	<ul style="list-style-type: none"> • Bad solder connection for the motor wiring to either motor solder lug. • Bad Motor 	

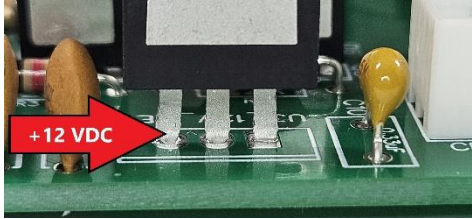
Symptom	Possible Solutions	
<p>The elevation motor does not turn at all.</p>	<p>Check for:</p> <ul style="list-style-type: none"> +12VDC on the output pin of the linear voltage regulator U3_12V_REG (see image below) 	<p>If measurement is bad:</p> <ul style="list-style-type: none"> Bad solder on voltage regulator pin(s) Damaged circuit board trace(s) Voltage regulator installed backwards Faulty voltage regulator
	<ul style="list-style-type: none"> The above reading is good 	<ul style="list-style-type: none"> Perform the checks for the elevation motor Down and Up movements

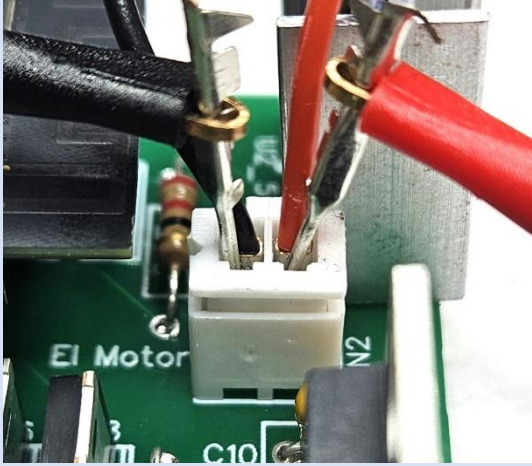
Symptom	Possible Solutions	
<p>The elevation motor does not turn clockwise (Down).</p>	<p>Check for: If measurement is bad:</p>	
	<p>The following measurement is performed with the black multimeter lead connected to the black wire of CN2 (EI Motor) and the red multimeter lead connected to the red wire of CN2 (EI Motor). Refer to the following image for one possible method for accomplishing this:</p>	
		
<ul style="list-style-type: none"> • About +11.7VDC while activating the manual elevation switch in the CW (Down) direction (toggle towards the yellow wire) 	<ul style="list-style-type: none"> • Bad solder on CN2 pins (Az Motor) • Q5 and/or Q6 and/or Q7 and/or Q8 installed backwards • Bad solder joints on any of the following components: Q5-Q8, R5-R8, D3, D4, C3, C4, C7, C8 • Either of the following components are faulty; Q5-Q8, D3, D4 • U3 is faulty – contact WA4MCMkits 	
<ul style="list-style-type: none"> • The above reading is good 	<ul style="list-style-type: none"> • Bad solder connection for the motor wiring to either motor solder lug. • Bad Motor 	

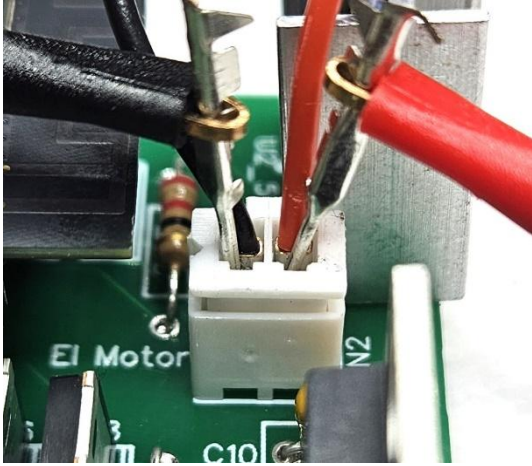
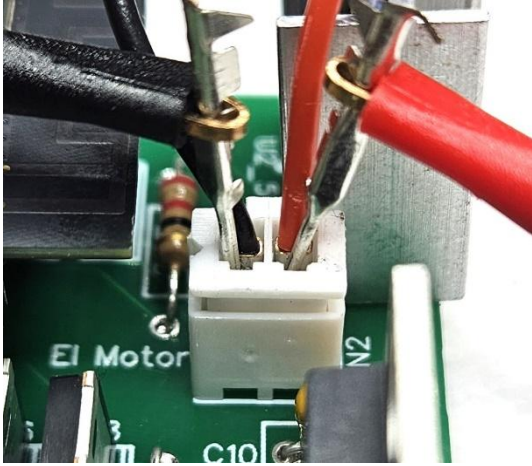
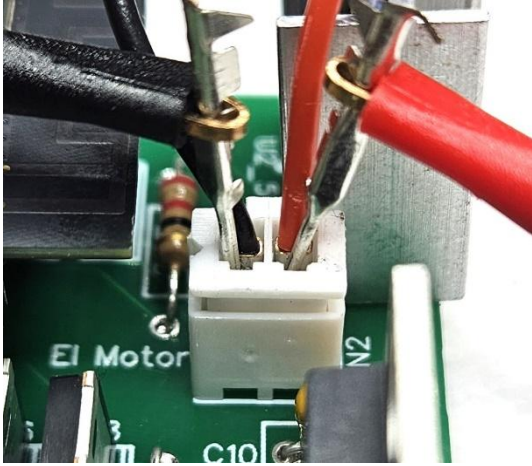
Symptom	Possible Solutions								
<p>The elevation motor does not turn counterclockwise (Up).</p>	<table border="1" style="width: 100%; border-collapse: collapse;"> <thead> <tr> <th style="width: 50%; text-align: left;">Check for:</th> <th style="width: 50%; text-align: left;">If measurement is bad:</th> </tr> </thead> <tbody> <tr> <td colspan="2" style="text-align: center;"> <p>The following measurement is performed with the black multimeter lead connected to the black wire of CN2 (EI Motor) and the red multimeter lead connected to the red wire of CN2 (EI Motor). Refer to the following image for one possible method for accomplishing this:</p>  </td> </tr> <tr> <td style="vertical-align: top;"> <ul style="list-style-type: none"> • About +11.7VDC while activating the manual elevation switch in the CCW (Up) direction (toggle towards the red wire) </td> <td style="vertical-align: top;"> <ul style="list-style-type: none"> • Bad solder on CN2 pins (Az Motor) • Q5 and/or Q6 and/or Q7 and/or Q8 installed backwards • Bad solder joints on any of the following components: Q5-Q8, R5-R8, D3, D4, C3, C4, C7, C8 • Either of the following components are faulty; Q5-Q8, D3, D4 • U4 is faulty – contact WA4MCMkits </td> </tr> <tr> <td style="vertical-align: top;"> <ul style="list-style-type: none"> • The above reading is good </td> <td style="vertical-align: top;"> <ul style="list-style-type: none"> • Bad solder connection for the motor wiring to either motor solder lug. • Bad Motor </td> </tr> </tbody> </table>	Check for:	If measurement is bad:	<p>The following measurement is performed with the black multimeter lead connected to the black wire of CN2 (EI Motor) and the red multimeter lead connected to the red wire of CN2 (EI Motor). Refer to the following image for one possible method for accomplishing this:</p> 		<ul style="list-style-type: none"> • About +11.7VDC while activating the manual elevation switch in the CCW (Up) direction (toggle towards the red wire) 	<ul style="list-style-type: none"> • Bad solder on CN2 pins (Az Motor) • Q5 and/or Q6 and/or Q7 and/or Q8 installed backwards • Bad solder joints on any of the following components: Q5-Q8, R5-R8, D3, D4, C3, C4, C7, C8 • Either of the following components are faulty; Q5-Q8, D3, D4 • U4 is faulty – contact WA4MCMkits 	<ul style="list-style-type: none"> • The above reading is good 	<ul style="list-style-type: none"> • Bad solder connection for the motor wiring to either motor solder lug. • Bad Motor
Check for:	If measurement is bad:								
<p>The following measurement is performed with the black multimeter lead connected to the black wire of CN2 (EI Motor) and the red multimeter lead connected to the red wire of CN2 (EI Motor). Refer to the following image for one possible method for accomplishing this:</p> 									
<ul style="list-style-type: none"> • About +11.7VDC while activating the manual elevation switch in the CCW (Up) direction (toggle towards the red wire) 	<ul style="list-style-type: none"> • Bad solder on CN2 pins (Az Motor) • Q5 and/or Q6 and/or Q7 and/or Q8 installed backwards • Bad solder joints on any of the following components: Q5-Q8, R5-R8, D3, D4, C3, C4, C7, C8 • Either of the following components are faulty; Q5-Q8, D3, D4 • U4 is faulty – contact WA4MCMkits 								
<ul style="list-style-type: none"> • The above reading is good 	<ul style="list-style-type: none"> • Bad solder connection for the motor wiring to either motor solder lug. • Bad Motor 								

CIRCUIT BOARD IMAGES

MAIN BOARD, MCU MODULE, AND ANALOG TO DIGITAL CONVERTER MODULE:

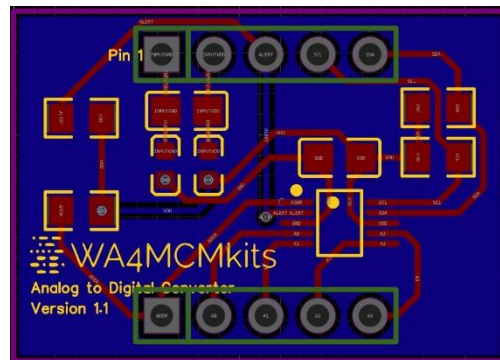
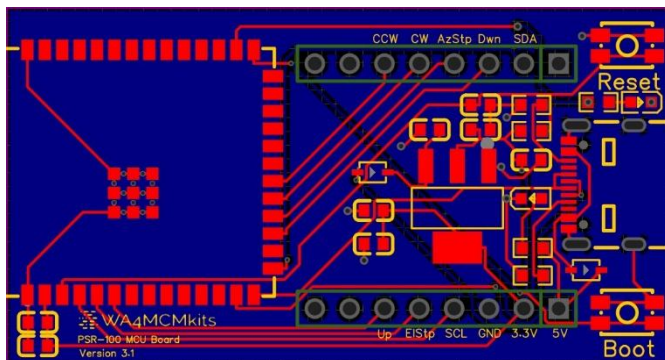
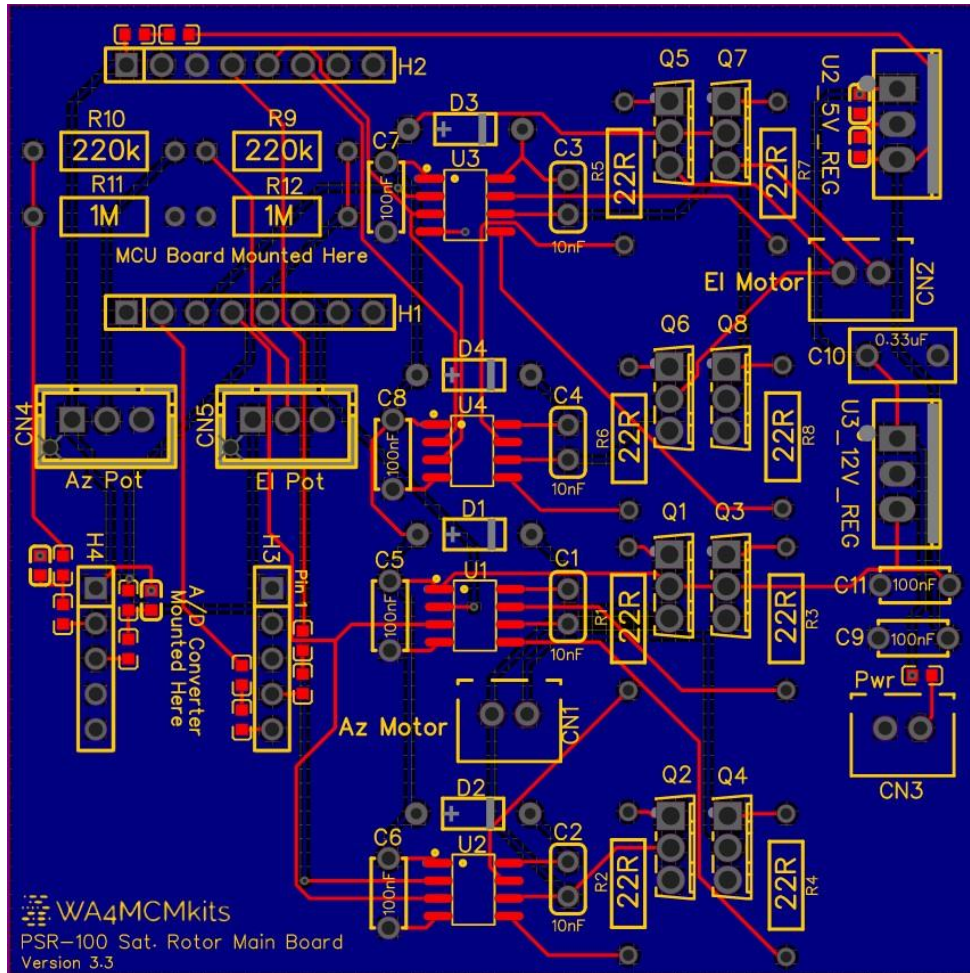

Yellow: Components mounted on the board's top side; green: components mounted on the board's underside.

WIFI ACCESS POINT MODULE BOARD:

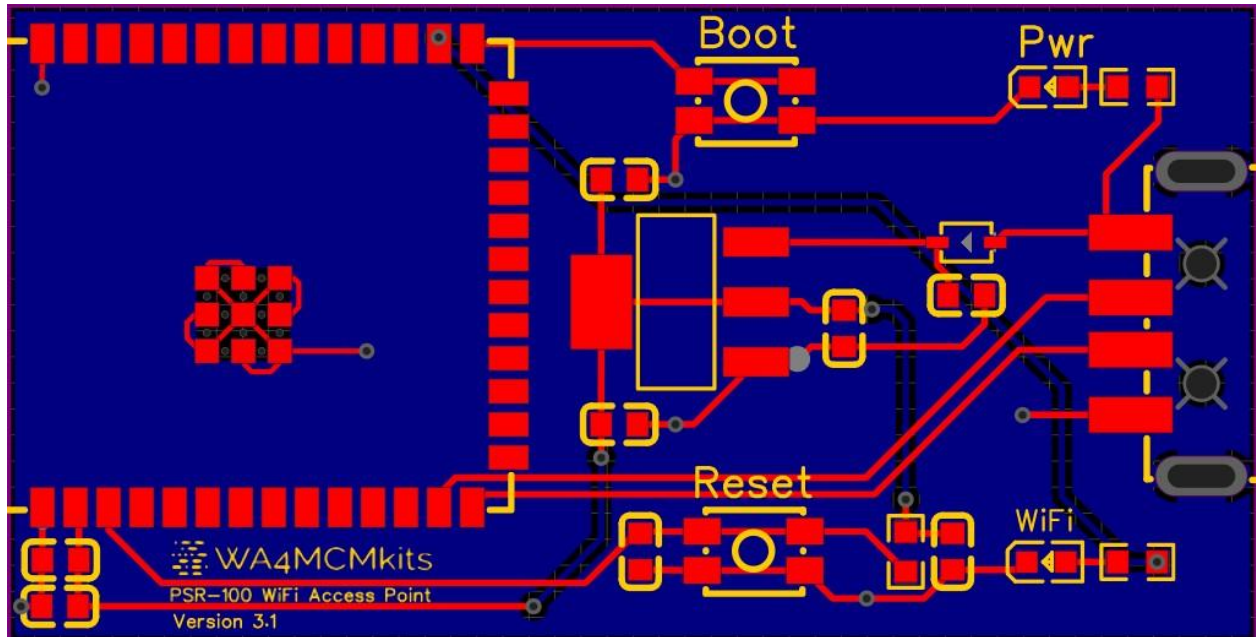

SCHEMATIC DIAGRAMS

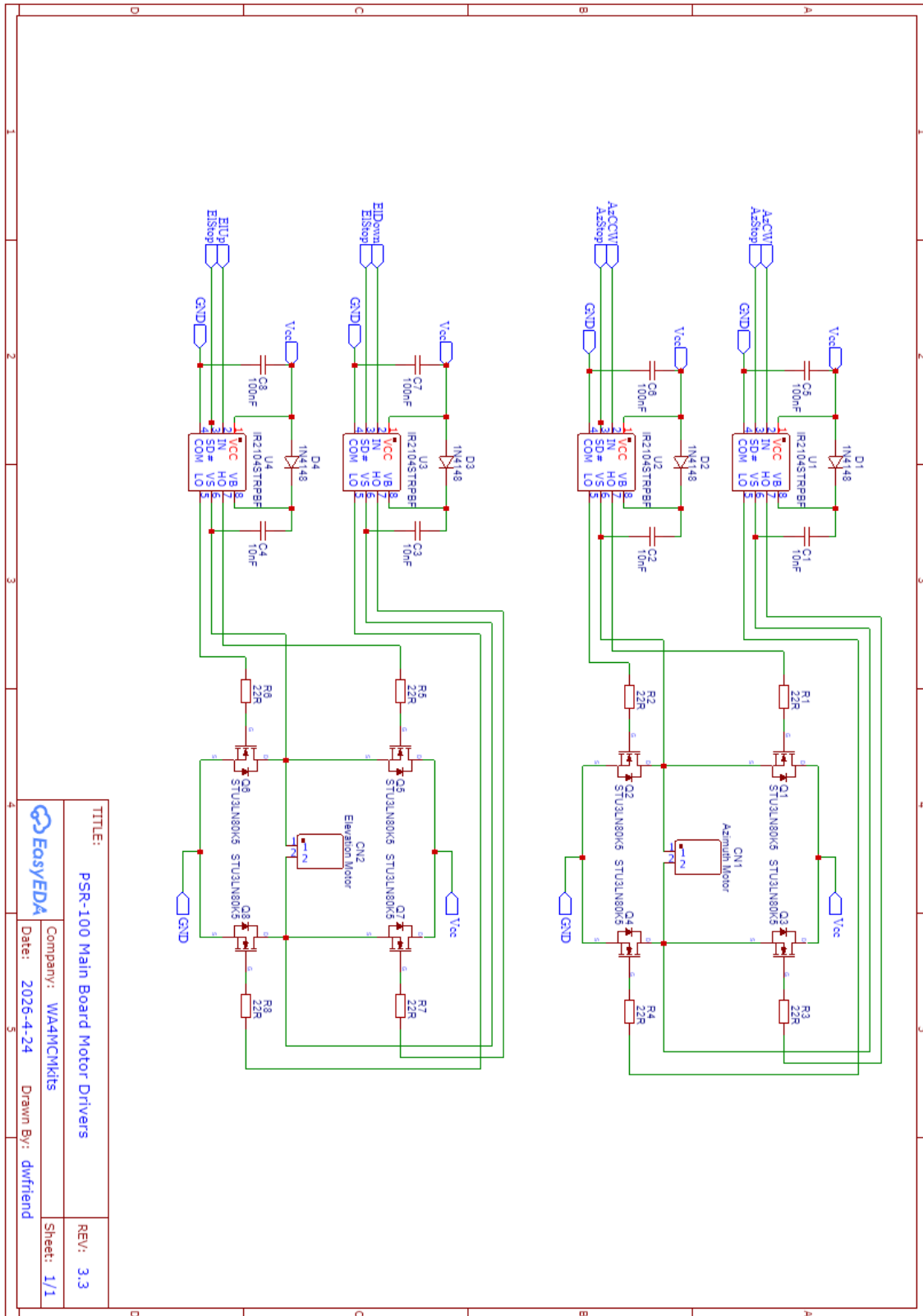

TITLE:		PSR-100 Main Board Motor Drivers	REV:	3.3
Company:		WA4MCMkits	Sheet: 1/1	
Date:	2026-4-24	Drawn By:	dvwfriend	

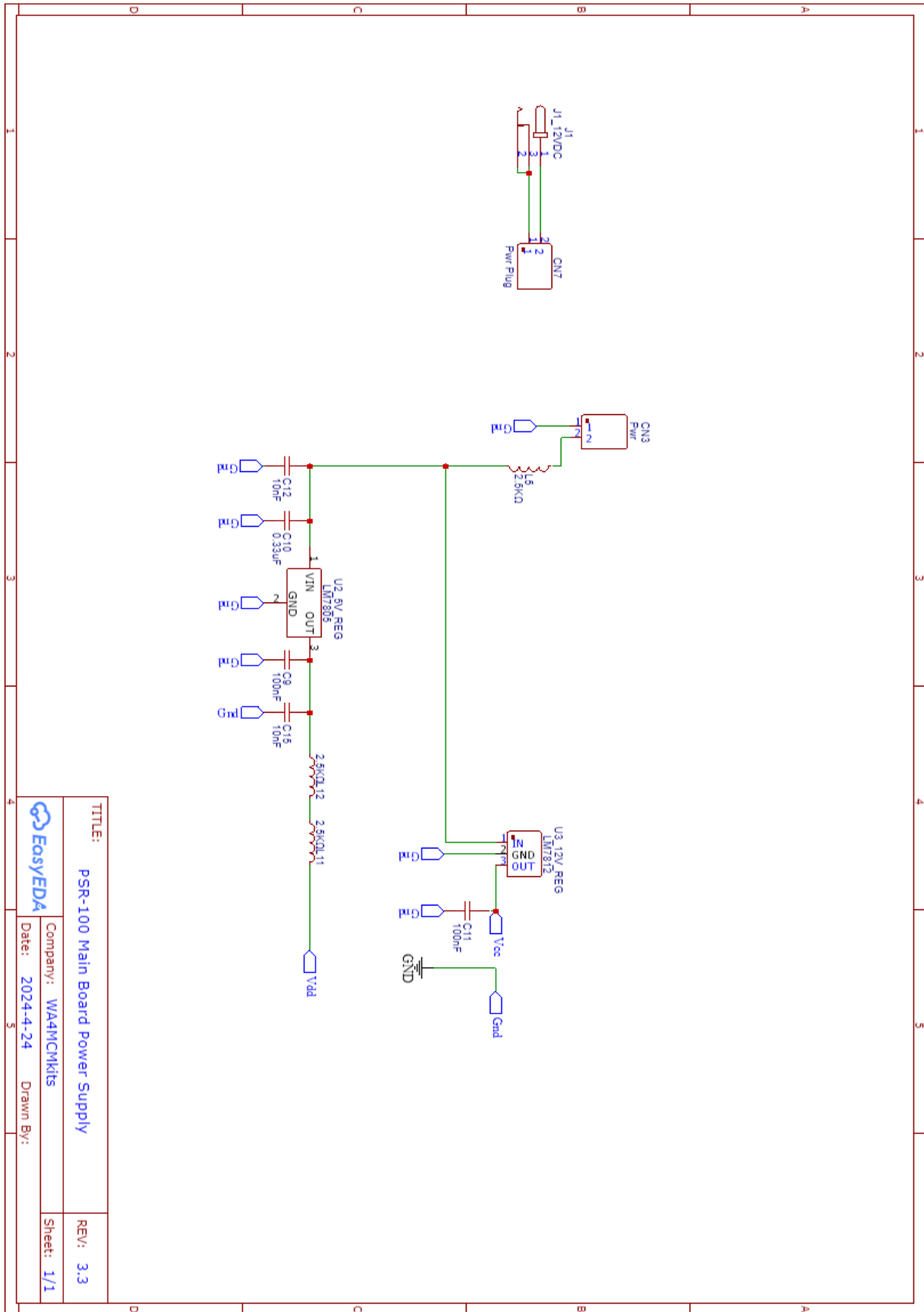

TITLE: PSR-100 Main Board Power Supply		REV: 3.3
Company: WA4MCMkits		Sheet: 1/1
Date: 2024-4-24		Drawn By: EasyEDA

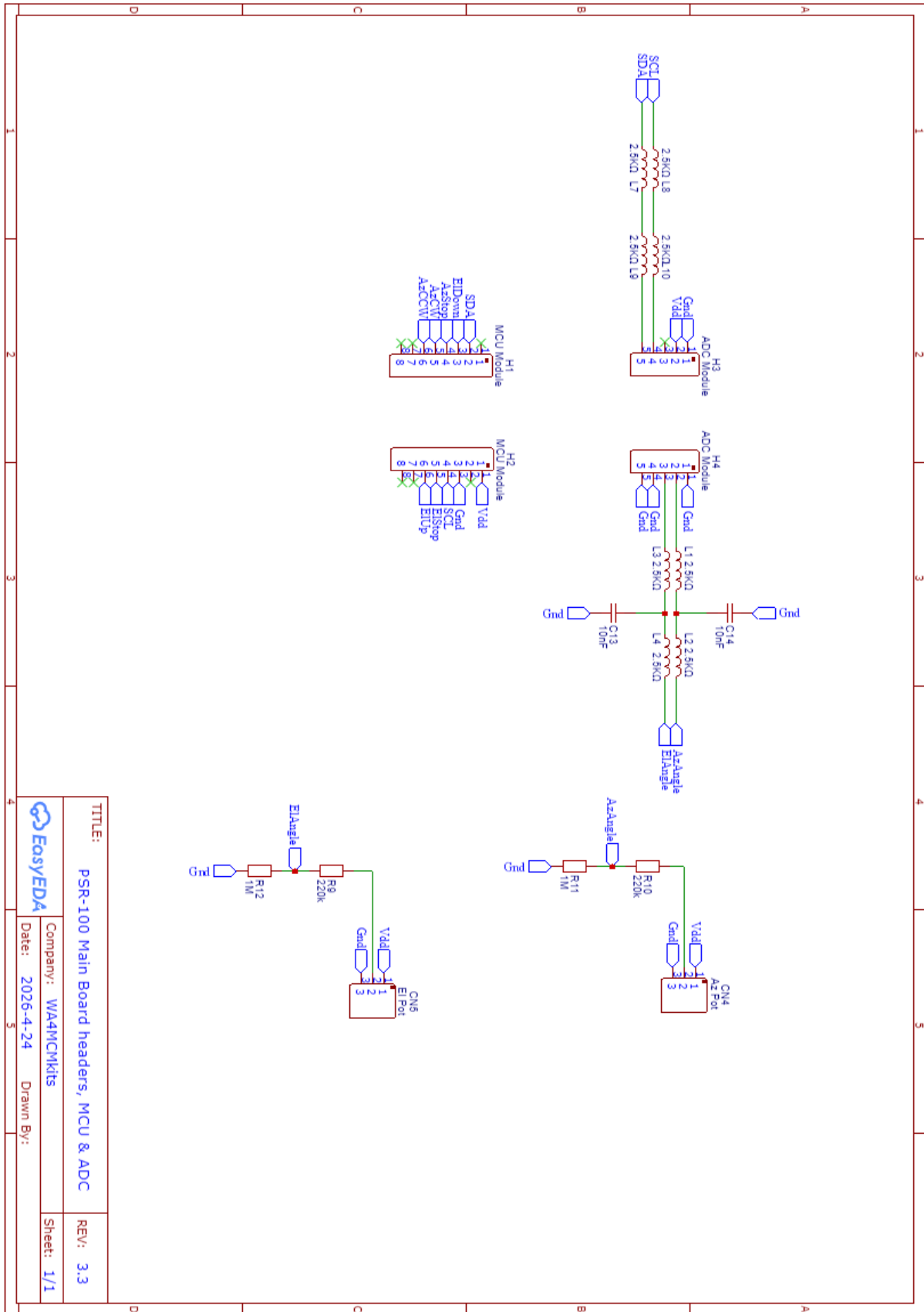

TITLE: PSR-100 Main Board headers, MCU & ADC		REV: 3.3
Company: WA4MCMkits		Sheet: 1/1
Date: 2026-4-24	Drawn By:	

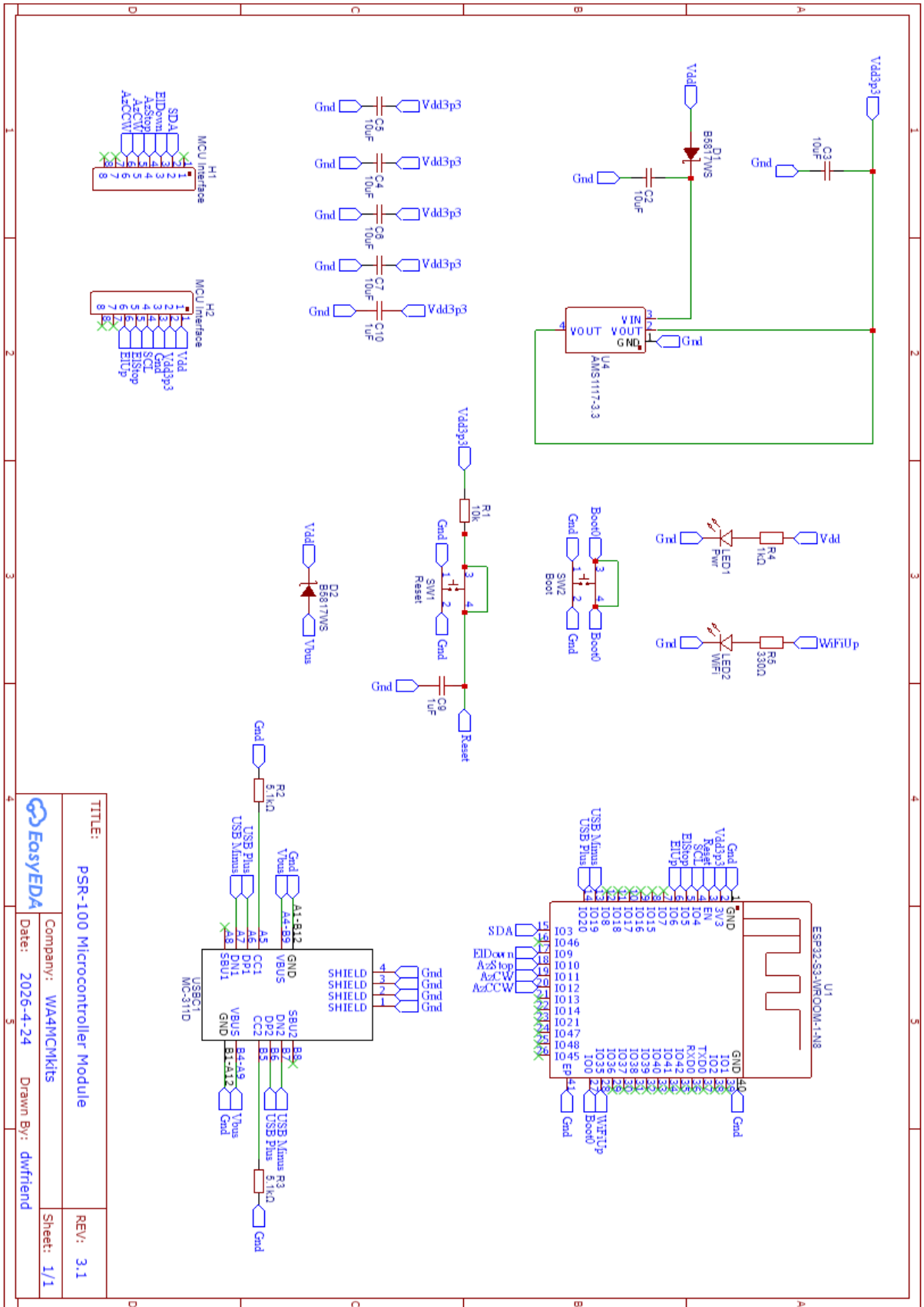

TITLE: PSR-100 Microcontroller Module		REV: 3.1
Company: WA4MCMkits		Sheet: 1/1
Date: 2026-4-24	Drawn By: dwfriend	

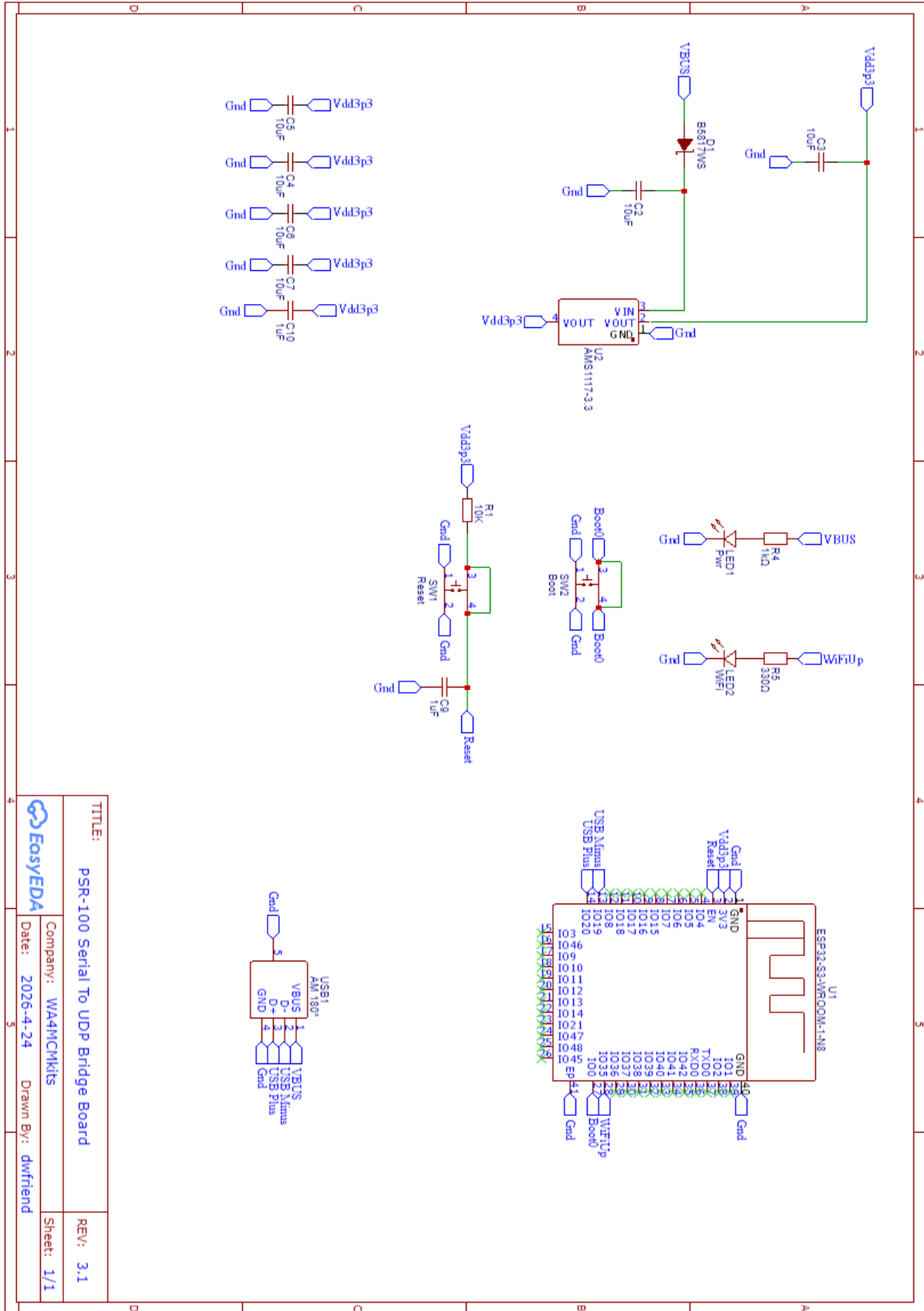

TITLE: PSR-100 Serial To UDP Bridge Board		REV: 3.1
Company: WA4MCMkits		Sheet: 1/1
Date: 2026-4-24	Drawn By: dwfriend	

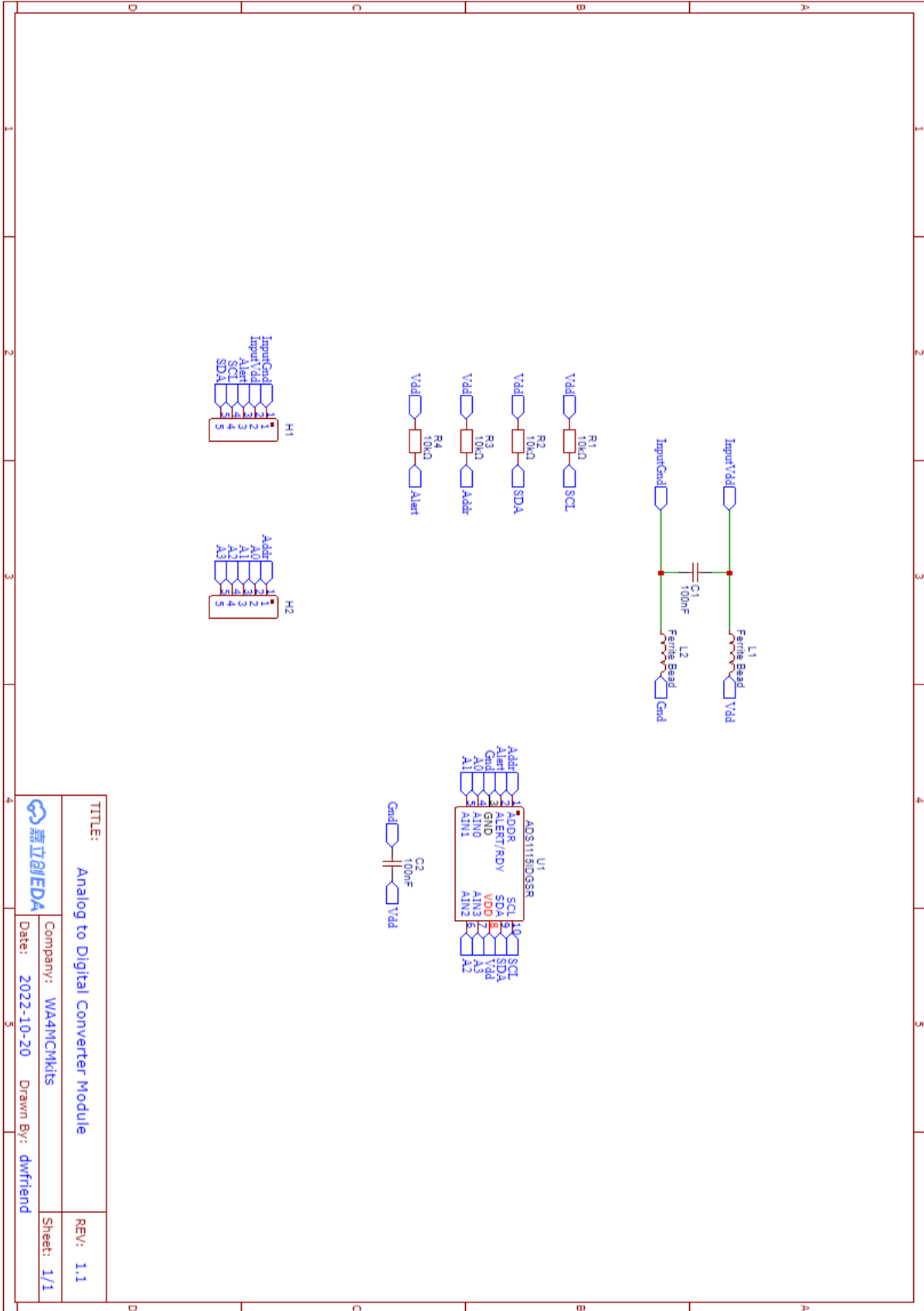

TITLE: Analog to Digital Converter Module		REV: 1.1
Company: WA4MCMkits		Sheet: 1/1
Date: 2022-10-20	Drawn By: dwfriend	